



TASCAM BD-MP1

CONTROL I/O Terminals

RS-232C/ETHERNET Protocol Specifications

Ver. 1.04

Jul. 2023

TEAC Corporation

CAUTION

TEAC Corporation (hereafter, "TEAC") permits the use of the protocol described in this specification document with the prerequisite that the customer consents to the following protocol use agreement conditions.

If you do not consent to the following conditions in the protocol use agreement, you may not use this protocol and should return this document to TEAC. Moreover, be aware that violations of any of the following items in the protocol use agreement is an infringement on the rights of TEAC and could result in the termination of further use and be subject to restitution claims, for example.

Protocol use agreement

1. This agreement comes into effect from the time the customer starts use of this protocol.
2. TEAC grants a nonexclusive and nontransferable "usage" right to the customer in order to develop devices (including software) that are compatible with the covered TASCAM products.
3. The acquisition of this document by the customer does not mean that the customer has acquired any rights, titles or interests in this protocol other than what is specified in this use agreement. The customer should recognize that as a written work belonging to TEAC, this document is protected based on the copyright laws of the signatory nations of the Universal Copyright Convention and the Berne Convention for the Protection of Literary and Artistic Works. Without exception, the intellectual property in this protocol belongs to TEAC or a source that provides it to TEAC.
4.
 - (1) The customer may not make copies of this specifications document.
 - (2) The customer may not transfer this specifications document to a third party without obtaining prior permission from TEAC.
 - (3) Since confidential information that belongs to TEAC is contained in this specifications document, the customer may not disclose it to a third party without obtaining prior permission from TEAC.
5. This specifications document and this protocol are provided as is. TEAC does not provide any guarantee whatsoever that the contents of this specifications document and the protocol are suitable for the specific purpose of the customer or that they are free of error.
6. TEAC cannot respond to customer inquiries about the contents of this specifications document.
7. TEAC will bear no responsibility for any damages (including business losses, business interruption, loss of business data or other financial damages) arising from the use or inability to use this specifications document or this protocol. This applies even if TEAC is informed about the potential for such damage in advance.

End of Use Agreement

1. Overview

The BD-MP1 ("controlled device") can be controlled from an external device ("external controller"), such as a computer, through a serial RS-232C and ETHERNET connection.

2. Specifications**2.1. Serial RS-232C****2.1.1. Electrical specifications**

Standard	JIS X-5101 (equivalent to the former JIS-C-6361 and EIA RS-232C standards) Note that this is not compatible with the RS-422 used in professional VTRs.
Impedance at receiver	When measured with an applied voltage between -3 V and +3 V or between -15 V and +15 V, the DC resistance is between 3k ohms and 7k ohms. Total load capacitance is 2500 pF or less.
Open circuit voltage at transmitter	25V or less
Open circuit voltage at receiver	2V or less
Signal voltage	When the open circuit voltage at the receiver is 0 V, the signal voltage is between -5 V and +5 V or between -15 V and +15V against a load impedance between 3k ohms and 7k ohms.
Signal discrimination	Logic "1": -3V or less Logic "0": +3V or more

2.1.2. Communication format

Circuit type	Asynchronous / Full-duplex
Transmission type	Digital binary serial
Data signal rate (baud rate)	115200 bits/sec
Data bits	8 bits
Parity bits	None
Stop bits	1 bit
Maximum data length	600 byte (Start character to End character is included.)

*Data signal rate, Data bits, Parity bits, and Stop bits are fixed.

2.1.3. Connector pin-out

Connector D-sub 9pin female (Inch screw thread)

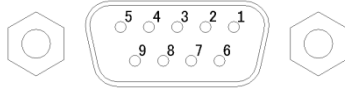

Terminal pin-out and input/output signals

Pin No.	In/Out	Signal name	Description
1	-	GND	Ground pin
2	Out	TxD	Data transmitted from this pin
3	In	RxD	Data received at this pin
4	-	NC	Not connected
5	-	S.GND	Signal ground pin
6	-	NC	Not connected
7	-	+5V Power	Can use 5V/500mA power supply
8	-	NC	Not connected
9	-	NC	Not connected

*Note

Pin 7 is the output terminal of the 5V power supply, so be careful when wiring the cable.

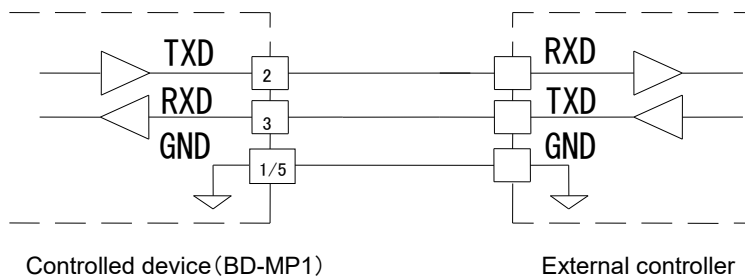

2.2. IP Control (Ethernet)

Transmission type Full duplex
 Transfer speed 10 / 100 Mbps
 TCP port No. 9030
 Maximum data length 600 Bytes (Start character to End character is included.)

3. Protocol Overview

The Serial Control Protocol consists of three command characters and parameter characters of variable length. Characters are the ASCII Code.

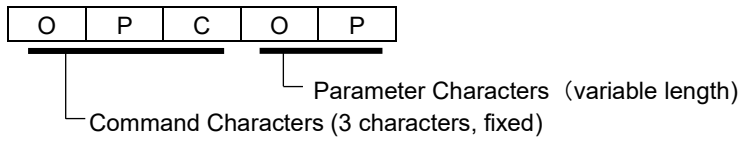

3.1 RS-232C Protocol

Controller -> Device Message Example

Disc Tray (Open)

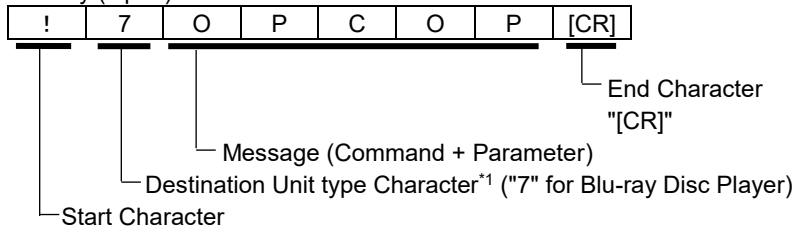

Special Character
 [CR] Carriage Return ASCII Code 0x0D

Device -> Controller Message Example

Status = Play

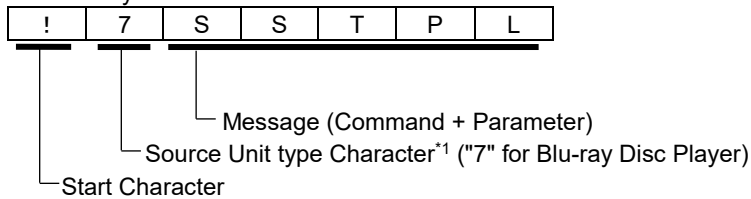

*1: Unit Type is the model category ID. The Blu-ray player is "7".

3.2 ETHERNET Protocol

Protocol is TCP. (Transmission Control Protocol)
 Destination Port Number is 9030. (fixed)

Controller -> Device Message Example

Disc Tray (Open)

1st Char	2nd Char	3rd Char	4th Char	5th Char	6th Char	7th Char	Last Char
!	7	O	P	C	O	P	[CR]

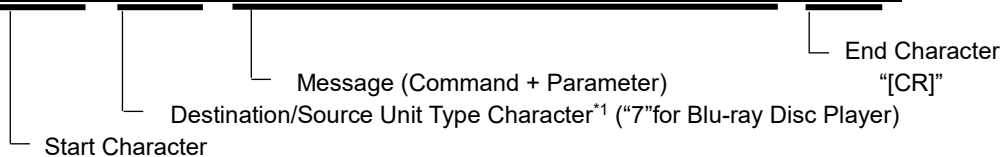

Special Character

[CR] Carriage Return ASCII Code 0x0D

Controller -> Device Message Example

Status = Play

1st Char	2nd Char	3rd Char	4th Char	5th Char	6th Char	Last Char
!	7	S	T	T	P	L

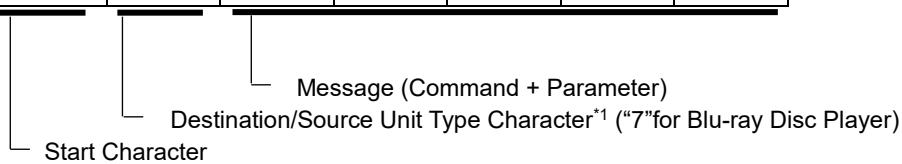

*1: Unit type is the model category ID. The Blu-ray player is "7".

Note:

After the connection is established between the device and the controller, the connection must stay.
 The controller cannot receive message status notifications from the device if the connection is lost.
 The device can only connect to one controller at a time.

4. Communication Protocol

4.1. Message Structure

There are three kinds of message, "COMMAND", "REQUEST", and "ANSWER /NOTIFICATION".

4.2. ACK(Acknowledge) and NACK(Not Acknowledge)

The device sends ACK or NACK to a controller according to the following table.

4.2.1. ACK

It is an affirmative reply sent to a controller from a device. When data transfer completes properly, a device notify of that to a controller.

4.2.2. NACK

It is a negative reply sent to a controller from a device. When data transfer does not complete properly, a device notify of that to a controller.

Name	Value(HEX)	Transmission Requirement
ACK	'ack' (0x61/0x63/0x6B)	The device acknowledged that the command was received normally from the controller.
NACK	'nack' (0x6E/0x61/0x63/0x6B)	<ul style="list-style-type: none"> • The device received the End Character 'CR(0x0D)' before receiving the Start Character '!(0x21)'. • The device does not receive ID'7(0x37)'just after Start Character'!(0x21)'. • The device receives an unknown character just after '!7'. • The device receives an unknown command just after '!7'. • Parameter is out of range. • The size of data is abnormal. • 5msec passed before the device receives the next code necessary to complete the command.

4.3. Communication Rules

4.3.1. Initiative of Communication

In the communication between a controller and a device, the controller must have the initiative.

However, the Status Information notification automatically from the device is an exception.

When the device receives a command from the controller, the device returns the following.

- When receiving the command which doesn't require a status information
ACK ('ack')
- When receiving the command which require a status information
ACK ('ack') + ('+') Status information (ANSWER)
- For the communication failure or an unknown commands etc.
NACK ('nack')

4.3.2. Communication Sequence

The controller must not send any new command after the previous command before the controller receives ACK or NACK, or the timeout (see "4.3.3. Timeout") has expired.

If the controller cannot check the device control status by status request or message status notification after sending a command, send a new command at intervals of 500msec or more after receiving ACK.

A status request command from the controller can be sent by waiting at least 50msec after ACK.

4.3.3. Timeout

After the controller sends the message to a device, the controller waits for a reply from the device for 30ms (IP Control) / 300ms (RS-232C). When the controller does not receive a reply over 30ms (IP Control) / 300ms (RS-232C) from the device, the controller sends the same message to the device. However, when the controller does not receive a reply from the device after sending the same message 3 times (that means Tim Out), the controller sends End character 'CR' (0x0D) to the device. After that, the controller should execute the recovery process such as retry.

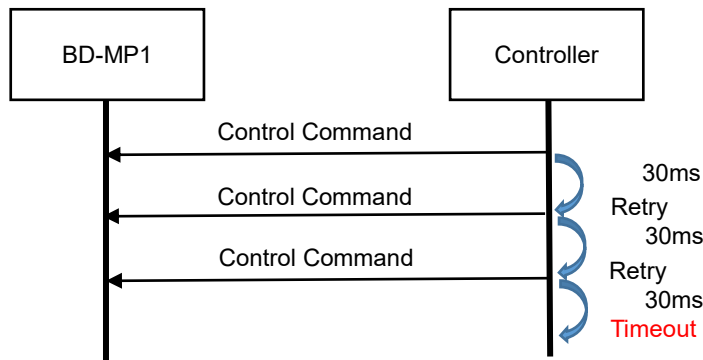

4.3.4. ACK

Refer to "4.2.1. ACK".

4.3.5. NACK

The device returns a NACK immediately after detecting a failure in the communication with the controller (see "4.2.2. NACK"). If the controller receives a NACK, it must stop sending the current remaining command immediately and execute the recovery process such as retry.

4.3.6. Command Interval time

- Interval time between Characters from a controller must be less than 5ms. The device sends NACK when 5msec passed before the device receives the next character code.
- Interval time between Commands is more than 30ms.

In case of less than 30ms as interval time between commands,

- 1) Executing the subsequent command is not guaranteed.
- 2) When there are buffer spaces of the device for a command, the device will execute the command.
- 3) When there is no buffer space of the device for a command, the device does not execute the command, and will send Busy (@0BDERBUSY) to the controller instead.

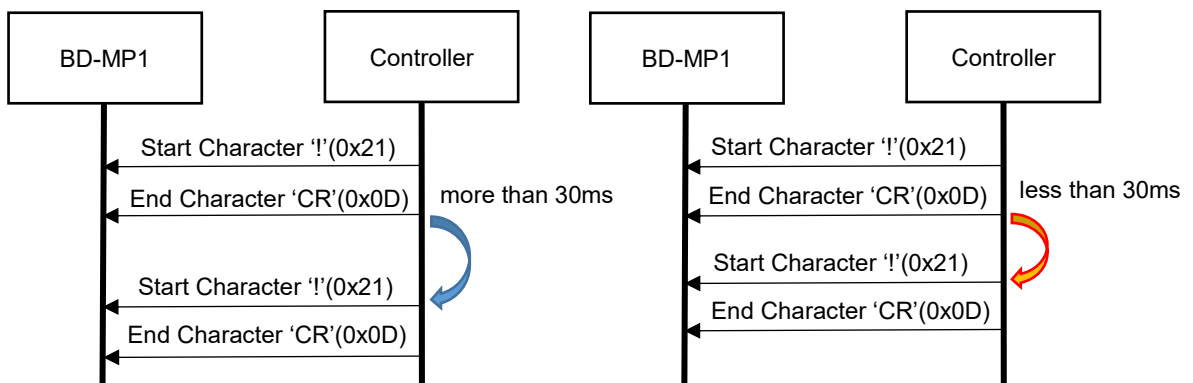

4.4. Basic Control Flow

4.4.1 Device Control Flow

The device sends the controller an ACK (Acknowledgement) and executes that command when the device receives a Control command from the controller. The list of the Control command is shown in "Control Command List".

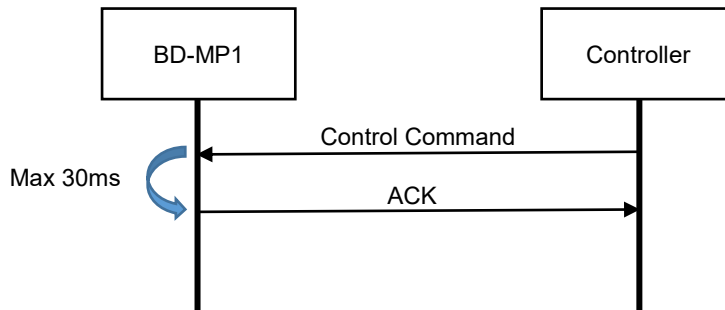

If the device receives an unknown command or an End Character 'CR' (0x0D) without a Start Character '!', it causes transmission failure and the device returns a NACK. Refer to "4.2.2. NACK" about NACK transmission condition.

4.4.2 Status Request Flow

The device returns an ACK and the ANSWER requested by the controller when the device receives the Status Request from the controller. The list of the Status Request and the corresponding answer is shown in "Status Request List"

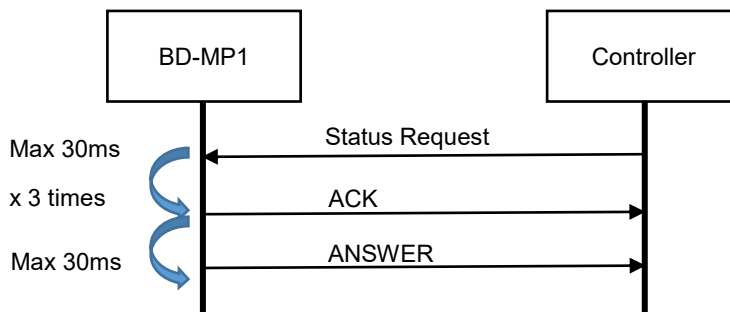

When a device receives Status Request from a controller, the device sends an ACK to the controller. After that, the device gets the current status, and then sends it to the controller.

If the device receives an unknown command or an End Character 'CR' (0x0D) without a Start Character '!', it causes transmission failure and the device returns a NACK. Refer to "4.2.2. NACK" about NACK transmission condition.

4.4.3 Status Notification Flow

The device notifies of Status Information listed in "Status Information List" whenever the status of the device is changed, such as the transport status, the current track, the storage media status, and other status.

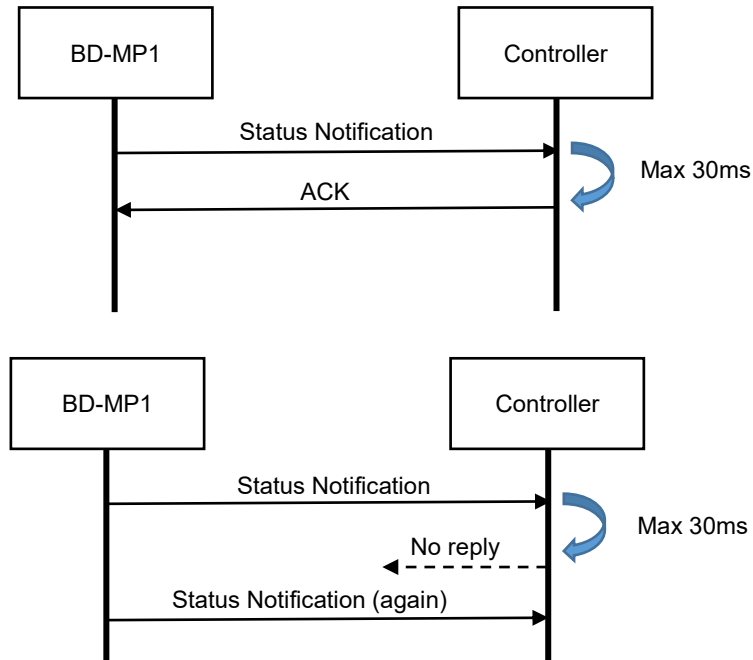

The device sends Status Notification to the controller. The controller replies ACK to the device. The device waits for the ACK for Max 30ms. When the device does not receive the ACK from the controller, the device sends the same Status Notification to the controller again. After that, the device does not send the same Status Notification even if it does not receive an ACK from the controller.

The Status Information is same as the answer for the Status Information listed in "Status Information List".

5. Command Table

Italic characters of command mean parameter. (Ex: Hide MENU “!7OSDXX” -> Parameter: XX)

*Note-“Track” means “Chapter” during the DVD or BD playback. “Group” means “Title”(DVD or BD playback) and “Folder”(USB and other playback).

5.1. Key Control

#	Function	Command/Response	Status Request	Description
1	Power On	!7PWR01	-	Power On *For Ethernet, the command is invalid.
2	Power Off	!7PWR00	-	Power Off *For Ethernet, the network will be disconnected.
3	Stop	!7STP	-	Stop
4	Play	!7PLY	-	Play
5	Play Pause	!7PAS	-	Playback is Paused
6	Chapter Jump	!7SKPnnnn	-	nnnn: DVD/BD Chapter, File No ('0001'-'2000')
7	Track/Chapter Jump Next	!7SKPNX	-	DVD/BD Chapter, File skip forward
8	Track/Chapter Jump Prev	!7SKPPV	-	DVD/BD Chapter, File skip reverse
9	Title Jump	!7GSKnnnn	-	nnnn: DVD/BD Title/CD Track No ('0001'-'2000')
10	Title Jump Next	!7GSKNX	-	DVD/BD Title, CD Track skip forward
11	Title Jump Prev	!7GSKPV	-	DVD/BD Title, CD Track skip reverse
12	Time Mode Code	!7TMDXX	!7?TMD	XX: Time Mode Code 'TL': Total Elapsed, 'TR': Total Remain, 'EL': Elapsed, 'RM': Remain,
13	Hide MENU	!7OSDXX	!7?OSD	Complete hiding of the menu/icon displayed on the screen. XX: On/Off '00': OSD on. '01': OSD off.
14	Setup Menu	!7SMN	-	Shows Setup menu.
15	Top Menu (Disc Menu)	!7TMN	-	Playback title menu in the disc.
16	Option Menu	!7OMN	-	Playback option menu.
17	Pop Up Menu	!7PMN	-	Shows Pop Up Menu in the disc.
18	Return	!7RET	-	Return to the previous setup menu screen in the BD/DVD disc.

19	Audio Dialog	!7ADGX	-	Selects dialog in the BD/DVD disc. X: Audio stream code '+': Primary '-': Secondary
20	Subtitle	!7SBT1	-	Selects subtitle language in the BD/DVD disc.
21	Enter	!7ENT	-	Decides selected item in the setup menu screen, etc. in the BD/DVD disc.
22	Disc Tray	!7OPCXX	-	Controls Disc Tray. XX: Disc Tray Open/Close 'OP': Open 'CL': Close
23	Video Resolution (Specified resolution)	!7RSCX	!7?RSC	Changes the resolution of HDMI X: Resolution '1': Auto, '2': 480/576i, '3': 480/576P, '4': 720P '5': 1080i, '6': 1080P
24	Display/Info	!7DSP	-	Shows information on screen display.
25	Function/Color	!7CBCX	-	Carries out a function peculiar to a disc. X: Color '1':Red, '2':Green, '3':Blue, '4':Yellow
26	Home	!7HOM	-	Shows HOME menu screen of the unit.
27	Ten Key	!7NUMX	-	Inputs 0-9 X: Number '1': 1, '2': 2, '3': 3, '4': 4, '5': 5, '6': 6, '7': 7, '8': 8, '9': 9, '0': 0
28	Slow/Search	!7SCNds	!7?SCN	d: Direction 'F' : Forward, 'R' :Reverse s: Search Speed 'f' : fast(cyclic 1,2,3,4,5) 's' : slow(cyclic 1/16,1/8,1/4,1/2,1) Note: 'Rs' (Reverse & slow) is not supported.
29	MUTE	!7MUTXX	!7?MUT	XX: On/Off '00': Mute on. '01': Mute off.
30	Cursor	!7OSDX	-	X: Direction of cursor movement. '1':Left, '2':Right, '3':Up, '4':Down

5.2. Menu Setting

#	Function	Command	Status Request	Response	Description
1	Disc Auto Playback	!7APL00	!7?APL	!7APL00	On(repeat off)
		!7APL01		!7APL01	Off
		!7APL02		!7APL02	On(repeat on)
2	PIP Mark	!7PMK00	!7?PMK	!7PMK00	On
		!7PMK01		!7PMK01	Off
3	HDMI 3D Output	!73DOAT	!7?3DO	!73DOAT	Auto
		!73DO01		!73DO01	Off
4	TV Aspect Ratio	!7ASC9W	!7?ASC	!7ASC9W	16:9 Wide
		!7ASC9A		!7ASC9A	16:9 Wide/Auto
		!7ASC3P		!7ASC3P	4:3 pan & scan
		!7ASC3L		!7ASC3L	4:3 letterbox
5	TV System	!7TVSNT	!7?TVS	!7TVSNT	NTSC
		!7TVSPL		!7TVSPL	PAL
		!7TVSMS		!7TVSMS	Multi-system
6	HDMI 1080p 24Hz Conversion	!7R1K00	!7?R1K	!7R1K00	On
		!7R1K01		!7R1K01	Off
7	HDMI Color Space	!7CLSRV	!7?CLS	!7CLSRV	RGB Video Level
		!7CLSRP		!7CLSRP	RGB PC Level
		!7CLSY4		!7CLSY4	YCbCr 4:4:4
		!7CLSY2		!7CLSY2	YCbCr 4:2:2
8	HDMI Deep Color	!7DPC48	!7?DPC	!7DPC48	48 Bits
		!7DPC36		!7DPC36	36 Bits
		!7DPC30		!7DPC30	30 Bits
		!7DPCOF		!7DPCOF	Off
9	Secondary Audio	!7SCA00	!7?SCA	!7SCA00	On
		!7SCA01		!7SCA01	Off
10	Fs Setting	!7COO48	!7?COO	!7COO48	48k LPCM
		!7COO96		!7COO96	96k LPCM
		!7COO19		!7COO19	192k LPCM
11	Speaker Configuration Down Mix Mode	!7SPCXX	!7?SPC	!7SPCXX	XX: Speaker /Woofer Number (Woofer Number is fixed to 1.) '21': 2.1Ch, '31': 3.1Ch '41': 4.1Ch, '51': 5.1Ch '61': 6.1Ch, '71': 7.1Ch

12	Speaker Configuration Speaker Setting	!7SPSdsvvvddd			<i>d</i> :Type 'C': center 'L': L 'R': R 'l': Ls 'r': Rs <i>s</i> :Size '0':Large, '1':Small <i>vv</i> : Level ex) '-01': -1dB, '+10': +10dB <i>ddd</i> : Delay 0005: 5msec
13	Firmware Upgrade	!7FWUUS	-	!7FWUUS	Via USB
		!7FWUDS		!7FWUDS	Via Disc
14	HDMI CEC	!7CCRH1	!7?CCR	!7CCRH1	HDMI1
		!7CCROF		!7CCROF	Off
15	Reset Factory Defaults	!7INI	-	!7INI	
16	BD-Live Network Access	!7LNA00	!7?LNA	!7LNA00	On
		!7LNALT		!7LNALT	Limited
		!7LNA01		!7LNA01	Off

5.3. Current Status Information

#	Function	Command	Response	Description
1	Power Status	!7?PWR	ACK	See "Key Control"
			No response	
2	Disc Status	!7?MST	!7MSTNC	There is not disc media
			!7MSTCI	There is disc media.
			!7MSTUF	Mounted media is unformatted. (unknown disc)
			!7MSTTO	Disc tray is opening or open
			!7MSTTC	Disc tray is closing or closed
			!7MSTTE	Disc tray error
3	Status	!7?SST	!7SSTPL	Play
			!7SSTPP	Pause
			!7SSTDV SX	Show play X: Direction 'R' : Reverse, 'F': Forward
			!7SSTDVFX	Search play X: Direction 'R' : Reverse, 'F': Forward
			!7SSTDV SU	Setup mode.
			!7SSTDVTR	Track Menu (Root Menu) playback in process.
			!7SSTDVHM	Home menu mode.
4	Total Track Number(4digit)	!7?STT	!7TTNXXXX	XXXX: Total Track
			Or !7TTXXXX *Status Notification	'0000' to '9999' 'UNKN': Unknown
5	Track Number	!7?STC	!7TNMXXXX	XXXX: Track No
			Or !7TNXXXX *Status Notification	'0000' to '9999' 'UNKN': Unknown
6	Total Group Number	!7?STG	!7TGNXXXX	XXXX: Total Group/Title '0000' to '9999' 'UNKN': Unknown
7	Group Number	!7?SGN	!7GNMXXXX	XXXX: Group/Title No. '0000' to '9999' 'UNKN': Unknown
8	Elapse Time	!7?SET	!7SET <i>hhmmss</i>	<i>hhmmss</i> : Time
9	Remain Time	!7?SRT	!7SRT <i>hhmmss</i>	<i>hhmmss</i> : Time

*Note-1

The acceptable character set is ISO/IEC8859-1.

	x0	x1	x2	x3	x4	x5	x6	x7	x8	x9	xA	xB	xC	xD	xE	xF
0x																
1x																
2x	<i>SP</i>	!	"	#	\$	%	&		()	*	+	,	-	.	/
3x	0	1	2	3	4	5	6	7	8	9	:	;	<	=	>	?
4x	@	A	B	C	D	E	F	G	H	I	J	K	L	M	N	O
5x	P	Q	R	S	T	U	V	W	X	Y	Z	[¥]	^	_
6x	`	a	b	c	d	e	f	g	h	i	j	k	l	m	n	o
7x	p	q	r	s	t	u	v	w	x	y	z	{		}	~	
8x																
9x																
Ax	<i>NBSP</i>	ı	¢	£	¤	¥	¦	§	¨	©	ª	«	¬		®	¯
Bx	°	±	²	³	´	µ	¶	·	¸	¹	º	»	¼	½	¾	¿
Cx	À	Á	Â	Ã	Ä	Å	Æ	Ç	È	É	Ê	Ë	Ì	Í	Î	Ï
Dx	Ð	Ñ	Ò	Ó	Ô	Õ	Ö	×	Ø	Ù	Ú	Û	Ü	Ý	Þ	ß
Ex	à	á	â	ã	Ä	å	æ	ç	è	É	ê	ë	ì	í	î	ï
Fx	ð	ñ	ò	ó	Ô	õ	ö	÷	ø	Ù	ú	û	ü	ý	þ	ÿ