

TASCAM

D01386220B

US-1x2HR

USB Audio Interface

REFERENCE MANUAL

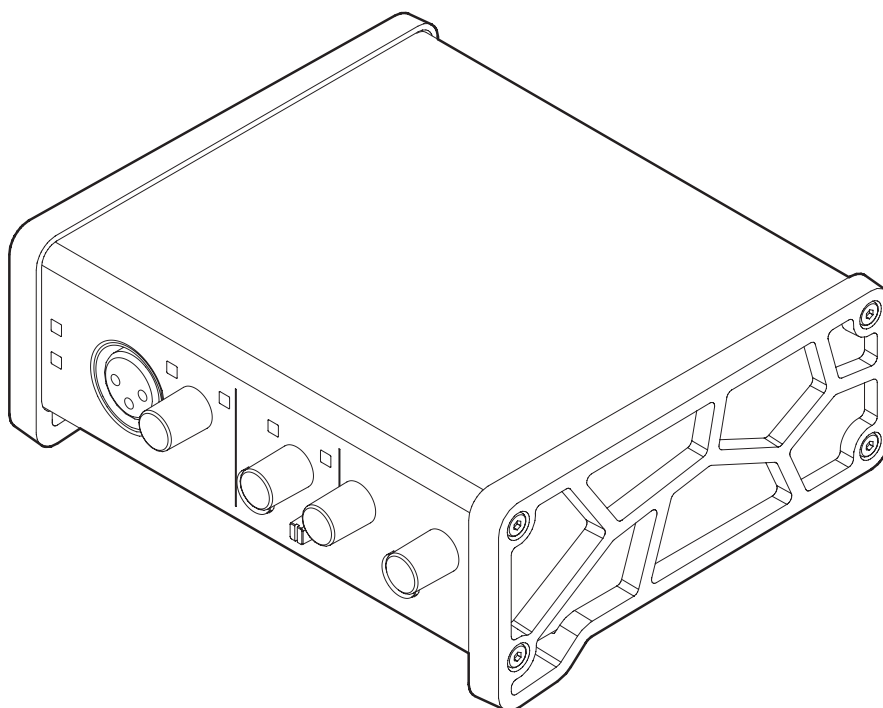

Before connecting this unit to a computer, you must download and install dedicated software on the computer.

Contents

1 – Introduction	3	9 – Specifications	19
Features	3	General	19
Conventions used in this manual	3	Input/output ratings	19
Trademarks	3	Analog inputs	19
2 – Names and Functions of Parts	4	Analog outputs	19
Front panel	4	Control input/output ratings	19
Rear panel	4	Audio performance	19
3 – Installation	5	Computer system requirements	20
System requirements	5	Windows	20
Windows	5	Mac	20
Mac	5	iOS device	20
Apple iOS devices	5	Supported audio drivers	20
Supported audio drivers	5	Other	20
Installing the dedicated software	6	Dimensional drawings	21
Installing the Windows dedicated software	6	Block diagram	21
Installing the Mac dedicated software	7		
Working with Gatekeeper	7		
Uninstalling the dedicated software	8		
Uninstalling the Windows dedicated software	8		
Uninstalling the Mac dedicated software	8		
4 – Preparation	9		
Connecting the power	9		
When using a computer (Windows/Mac)	9		
When using an iOS device	9		
Connecting other equipment	9		
Connecting with a computer	10		
Connecting with iOS devices	10		
Audio connections	10		
Using direct monitoring	11		
5 – Using the Settings Panel	12		
Opening the Settings Panel	12		
Windows	12		
Mac	12		
Settings Panel overview	12		
Notification function	13		
Checking software and firmware versions	13		
Automatic software and firmware update function	14		
6 – Application Guide	15		
DAW software	15		
Bundled DAW software	15		
Other DAW software	15		
Windows	15		
macOS	15		
iOS	15		
7 – Standalone Mode	16		
Overview	16		
Settings in standalone mode	16		
Settings Panel settings	16		
8 – Troubleshooting	17		

Features

- Support for high resolution formats up to 24-bit/192kHz
- XLR mic and standard TRS jack inputs
- Ultra-HDDA (High Definition Discrete Architecture) mic preamp with clear, natural sound quality and super-low noise
- Capable of providing +48V phantom power
- Support for direct input of guitars, basses and similar instruments
- RCA stereo line inputs
- RCA stereo line and headphone outputs
- Direct monitoring function allows input monitoring with low latency
- Loopback function that supports stereo/mono switching of inputs and outputs (on Windows/Mac)
- USB Type-C port (USB 2.0 standard)
- Support for operation on USB bus power
- US-HR Settings Panel control software has a simple, functional design and enables making unit settings
- High-performance driver can be set to minimal buffer sizes and enables recording setups with super-low latency (Windows)
- Angled design provides excellent usability on a desktop
- Valuable bundled software
- Connect with iOS devices including iPad

Note about computer operation

If you are unsure about anything related to the basic operation of a computer when it is mentioned in an explanation in this manual, please refer to the computer operation manual.

To use this unit with a computer, dedicated software must be installed on the computer.

For details about software installation, see “Installing the dedicated software” on page 6.

Conventions used in this manual

In this manual, we use the following conventions:

- Information shown on a computer display is written like this: “OK”.
- References to “iOS” in this document also include “iPad OS”.
- As necessary, additional information is provided under TIP, NOTE and CAUTION headings.

TIP

These are tips about how to use the unit.

NOTE

These provide additional explanations and describe special cases.

ATTENTION

Failure to follow these instructions could result in damage to equipment or lost data, for example.

CAUTION

Failure to follow these instructions could result in injury.

Trademarks

- TASCAM is a registered trademark of TEAC Corporation.
- Microsoft and Windows are either registered trademarks or trademarks of Microsoft Corporation in the United States and/or other countries.
- Apple, Mac, macOS, iOS, iPadOS, iPad and iPod touch are trademarks of Apple Inc. in the United States and other countries.
- Lightning is a trademark of Apple Inc.
- App Store is a service mark of Apple Inc.
- IOS is a trademark or registered trademark of Cisco in the U.S. and other countries and is used under license.
- ASIO is a trademark of Steinberg Media Technologies GmbH.



- Other company names, product names and logos in this document are the trademarks or registered trademarks of their respective owners.

2 - Names and Functions of Parts

Front panel

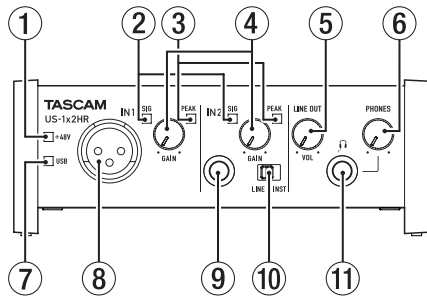

① PHANTOM indicator

The indicator lights when the phantom power switch (19) of the rear panel is set to "ON".

② SIG indicators

The SIG indicators light green when signals (of at least -32 dBFS) are input through the IN1/IN2/LINE IN L-R jacks (8/9/17).

③ PEAK indicators

The PEAK indicators light red when signals that are about to distort (-1 dBFS or higher) are input through the IN1/IN2/LINE IN L-R jacks (8/9/17).

④ GAIN knobs

Use to adjust the input levels of the IN1/IN2 jacks (8/9).

⑤ LINE OUT knob

Use to adjust the output level of the LINE OUT L and R (18) jacks on the back of the unit.

⑥ PHONES knob

Use to adjust the output level of the PHONES jack (11).

⚠ CAUTION

Before connecting headphones, minimize the volume with the PHONES knob. Failure to do so could result in a sudden loud noise that could harm hearing, for example.

⑦ USB indicator

This lights when the USB connection is working.

⑧ IN1 jack

This mic level XLR jack is a balanced input jack.

⑨ IN2 jack

This input jack is a standard TRS jack.

Use the LINE/INST switch (10) on the front of the unit to enable balanced line (LINE) input or unbalanced (INST) input for the standard TRS jack.

⑩ LINE/INST switch

Set according to the IN2 jack (9) input sources.

Set to LINE when connecting electronic instruments, audio devices and similar equipment. Set to INST when connecting a guitar, bass or other equipment with high output impedance.

⑪ PHONES jack

Use this standard stereo jack to connect stereo headphones.

This jack outputs the same signal of the rear panel as the LINE OUT L-R jacks (18).

Use an adapter to connect headphones with a mini plug.

Rear panel

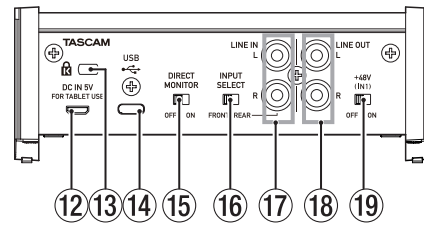

⑫ DC IN 5V connector (Micro USB type)

When connected to an iOS device or other equipment that cannot power this unit, you must use a USB power adapter, mobile battery or other power supply. See "When using an iOS device" on page 9 for details.

⑬ Kensington Security Slot

⑭ USB port

This is a USB Type-C port.

Use a USB cable to connect the unit to a computer or an iOS device.

ATTENTION

- When using this unit while connected to a computer, it will receive power from the computer's USB port. Depending on the computer, the USB port might not be able to supply enough power to operate the unit. In this case, connect and use a dedicated AC adapter.
- When connected to a USB 3.0 port, it will function in High Speed mode equivalent to USB 2.0 (480 Mbps maximum).
- After waking a computer from suspend (sleep) mode, if the unit does not operate properly, turn it off and turn it on again or disconnect and reconnect the USB cable.

⑮ DIRECT MONITOR switch

Turning this switch ON enables the Settings Panel Monitor Balance slider and input monitoring without delay (direct monitoring). (see "Using direct monitoring" on page 11)

⑯ INPUT SELECT switch

Set according to the input sources.

Set to FRONT when connecting to IN1/IN2 jacks (8/9) of the front panel. Set to REAR when connecting to LINE IN L-R jacks (17) of the rear panel.

⑰ LINE IN L-R jacks

These RCA pin jacks are analog line inputs.

⑱ LINE OUT L-R jacks

These RCA pin jacks are analog line outputs.

⑲ Phantom power switch

Use this switch to provide +48V phantom power to the IN1 jack (8).

System requirements

Check the TEAC Global Site (<https://teac-global.com/>) for the latest information about supported operating systems.

Windows

Supported operating systems

Windows 10 32-bit
Windows 10 64-bit
Windows 8.1 32-bit
Windows 8.1 64-bit
Windows 7*
 Windows 7 32-bit SP1 or later
 Windows 7 64-bit SP1 or later

* Operation has been confirmed with the final version of Windows 7.

Computer hardware requirements

Windows computer with a USB 2.0 (or higher) port

CPU/processor speed

2 GHz or faster dual core processor (x86)

Memory

2 GB or more

ATTENTION

Operation of this unit was confirmed using standard computers that meet the above requirements. This does not guarantee operation with all computers that meet the above requirements.

Even computers that meet the same system requirements might have processing capabilities that differ according to their settings and other operating conditions.

NOTE

Since noise could occur depending on the computer system used, we recommend selecting “*High performance*” for “*Plugged in*” on the Power Options Control Panel page.

Mac

Supported operating systems

macOS Catalina (10.15)
macOS Mojave (10.14 or later)
macOS High Sierra (10.13 or later)

Computer hardware requirements

Mac with a USB 2.0 (or higher) port

CPU/processor speed

2 GHz or faster dual core processor

Memory

2 GB or more

Apple iOS devices

Supported operating systems

iPadOS13
iOS13
iOS12
iOS11

Supported audio drivers

Windows

ASIO2.0, WDM

Mac

Core Audio

iOS device

Core Audio

3 – Installation

Installing the dedicated software

To use this unit, a dedicated software must be installed on a computer.

The dedicated software might be updated at any time.

Download the latest software for the operating system you are using from the TEAC Global Site (<https://teac-global.com/>).

- When you install the dedicated software on a Windows computer, the Windows driver and the Settings Panel application will be installed.
- When you install the dedicated software on a Mac, only the Mac Settings Panel application will be installed. The standard OS driver will be used.
- With an iOS device, the standard OS driver will be used, so there is no need to install any. To change unit settings, use the Settings Panel application installed on a Windows or Mac computer.

ATTENTION

Before starting to install software, quit other applications.

Installing the Windows dedicated software

ATTENTION

- Complete installation of the Windows dedicated software on the computer before connecting the unit to it with the USB cable.
- If you connected the unit to the computer using the USB cable before installing the Windows dedicated software and the *“Found New Hardware Wizard”* launched, close the Wizard and disconnect the USB cable.

Windows dedicated software installation procedures

1. Download the latest Windows dedicated software from the TEAC Global Site (<https://teac-global.com/>) and save it on the computer to be used with the unit.
2. Uncompress the saved software (zip file) on the computer desktop or another location.
3. Double-click the *“TASCAM_US-HR_Installer_x.xx.exe”* file in the folder that appears after uncompression to automatically launch the installation software.

ATTENTION

If you open a zip file without decompressing it and doubleclick the *“TASCAM_US-HR_Installer_x.xx.exe”* file in the folder that opens, installation will not start. Right-click the zip file and select *“Extract All”*, for example, to decompress it and then try again.

4. When a *“Security Warning”* or *“User Account Control”* screen appears, click the *“Yes”* button.

5. Read the contents of the License Agreement, and select *“I accept the agreement”* if you agree to the terms. Then, click the *“Next”* button.

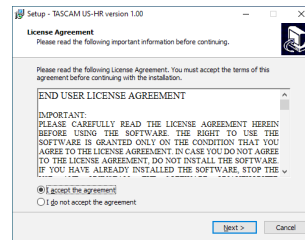

6. Next, click the *“Install”* button.

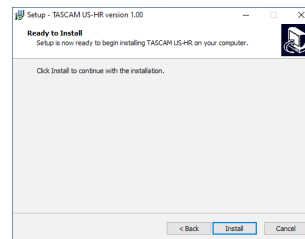

7. Next, click the *“Install”* button to start installation (Windows 8.1/Windows 7).

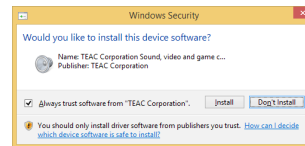

8. The following screen appears when installation has completed. Click the *“Finish”* button.

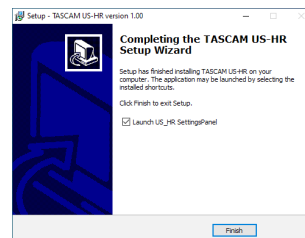

The installer will quit and the Windows Settings Panel will launch.

NOTE

The first time you connect the unit by USB to the computer after installing the software, installation of the device driver will be executed. Some time might be necessary before the unit is recognized because Windows Update will be automatically searched at this time.

If the unit is still not recognized after a while, open the software installation screen from the notification area at the bottom right of the computer display, and click *“Skip obtaining driver software from Windows Update”* to stop the search.

Installing the Mac dedicated software

NOTE

- Install the Mac dedicated software on the computer before connecting the unit to it with the USB cable.
- Depending on the Gatekeeper setting, a warning message might appear during installation. Please see “Working with Gatekeeper” on page 7 for information about Gatekeeper.

Mac dedicated software installation procedures

1. Download the latest Mac dedicated software for the operating system you are using from the TEAC Global Site (<https://teac-global.com/>) and save it on the computer to be used with the unit.
2. Double-click “US-HR_Installer_x.xx.dmg”, which is the saved disk image file for the Mac dedicated software, and double-click “US-HR_Installer.pkg” inside the folder that opens.

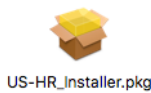

NOTE

Depending on the computer’s settings, the downloaded zip file might not have been uncompressed automatically. In this case, unzip the zip file first and then double-click the disk image file.

3. When the installer starts, click the “Continue” button.

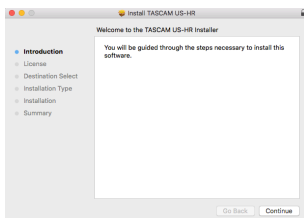

4. Next, select the desired language and click the “Continue” button.

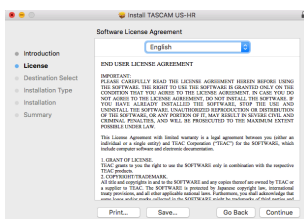

5. Click the “Read License” button and check the contents of the Software License Agreement. If you agree to the contents of the license, click “Agree”. Then, click the “Next” button.

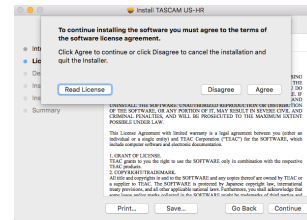

6. Next, click the “Install” button to start installation.

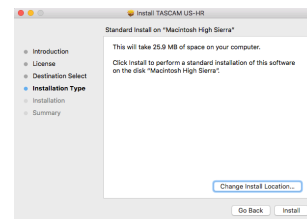

7. The following screen appears when installation has completed. Click the “Close” button.

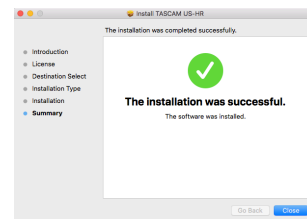

Working with Gatekeeper

When using macOS, depending on the Gatekeeper security function setting, a warning message might appear during installation.

The solution depends on the warning message shown. See the following explanations for details.

When the Gatekeeper setting is “Allow applications downloaded from: the Mac App Store”

The following security warning might be shown:

“US-HR_Installer.pkg” can’t be opened because it was not downloaded from the Mac App Store.”

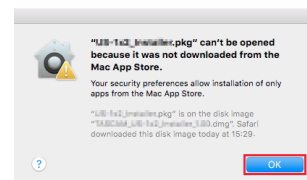

In this case, click the “OK” button to close the message. Then, control-click (or right-click) the file and click “Open” in the menu.

3 – Installation

When the *“US-HR_Installer.pkg” can’t be opened because it was not downloaded from the Mac App Store. Are you sure you want to open it?* security warning message appears, click the *“Open”* button.

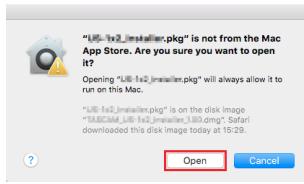

This warning message might also appear when the Gatekeeper setting is something other than *“Allow applications downloaded from: the Mac App Store”*. The file still might not open and *“US-HR_Installer.pkg” can’t be opened because it was not downloaded from the Mac App Store.* might appear again.

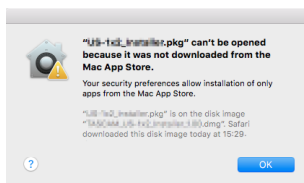

In this case, copy the file from the folder where it is to the desktop or another folder, and then open it. Alternatively, change the Gatekeeper settings to *“Allow apps downloaded from: App Store and identified developers”* and try opening it again.

When the Gatekeeper setting is *“Allow applications downloaded from: the Mac App Store”*

“US-HR_Installer.pkg” is an application downloaded from the Internet. Are you sure you want to open it? might appear as a security warning message. In this case, click the *“Open”* button.

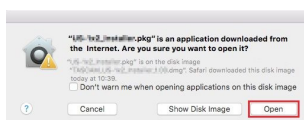

Changing the Gatekeeper setting

The Gatekeeper setting can be changed using the *“Allow applications downloaded from:”* item on the *“General”* page of the *“Security & Privacy”* pane of the System Preferences. To change this, you must click the lock icon (🔒) at the bottom left and enter a password to unlock the settings.

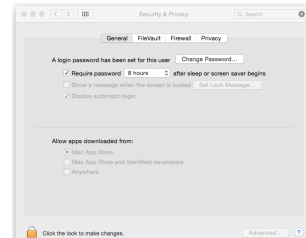

This setting will lock again when you close the System Preferences by clicking the 🔒 button or typing command-Q, for example, or when you click *“Show All”* to close the open pane.

ATTENTION

Changing the Gatekeeper settings could result in security risks.

If you changed the Gatekeeper setting to decrease security (use one of the lower settings), set it back to the original setting after updating the software and/or firmware. (When installing a firmware update immediately after software, do this after installing the firmware update.)

Uninstalling the dedicated software

NOTE

Normally, there is no need to uninstall the dedicated software.

Follow these procedures if a problem occurs or you no longer intend to use the unit with the computer.

Uninstalling the Windows dedicated software

1. Open the *“Uninstall or change a program”* screen using the procedures for the operating system being used (Windows 10/Windows 8.1/Windows 7).
2. Select *“TASCAM US-HR version x.xx”* from the list, and double-click it.
3. Then, follow the instructions that appear on the screen.

Uninstalling the Mac dedicated software

Delete *“US-HR_SettingsPanel”* from the Applications folder to complete uninstallation.

4 – Preparation

Connecting the power

When using a computer (Windows/Mac)

When this unit is connected to a computer using an included USB cable, it will operate using USB bus power, so connecting a separate power supply device is not necessary.

When using an iOS device

When this unit is connected to an iOS device, connecting an external battery, USB power adapter or other power supply device is necessary in order to power the unit.

Connect an AC adapter (TASCAM PS-P520E), external battery pack (TASCAM BP-6AA) or the genuine Apple USB power adapter included with the iPad/iPhone to a USB cable (sold separately), and connect it to the DC IN 5V port.

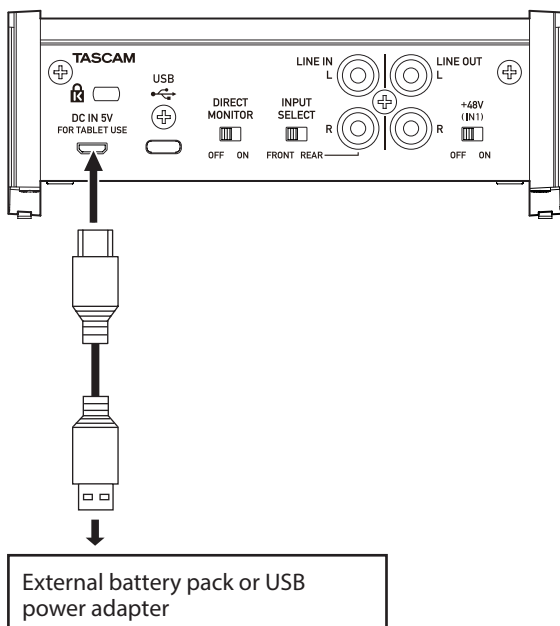

ATTENTION

- Provide power through the DC IN 5V connector before connecting an iPad/iPhone by USB.
- No USB power adapter is included with an iPod touch. To use it with an iPod touch, purchase a genuine Apple USB power adapter (that can supply 5 V and a current of at least 700 mA) separately.
- Operation with other external battery packs and USB power adapters is possible, but we strongly recommend using a TASCAM PS-P520E AC adapter, TASCAM BP-6AA external battery pack or the genuine Apple USB power adapter included with the iPad/iPhone.

When using another external battery pack or USB power adapter, be sure that the power supply device meets the following specifications.

- Supplied voltage: 5 V
- Supplied current: 700 mA or more

Using a power supply device when the specifications are other than the above could cause malfunction, overheating, fire or other problems. If anything abnormal occurs, stop use and contact the retailer where you purchased the unit or a TASCAM customer support service to request repair.

Connecting other equipment

This is an example of US-1x2HR connections.

Precautions before making connections

- Carefully read the operation manuals of the devices to be connected and then connect them correctly.
- Before making connections, turn this unit and all equipment to be connected off (standby).
- Install all connected devices, including this unit, so that they are powered from the same line. When using a power strip or similar device, be sure to use one that has high current capacity (thick cable) in order to minimize fluctuations in power voltage.

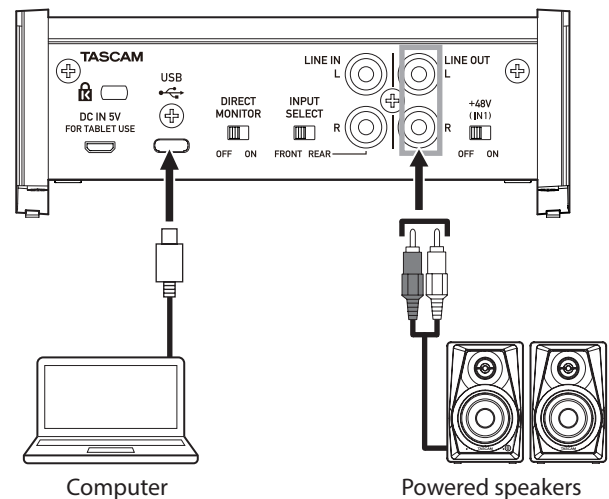
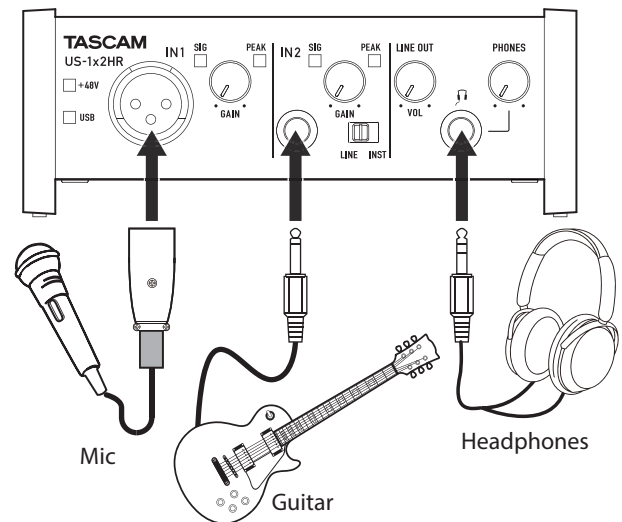

Examples of connections to a US-1x2HR

4 – Preparation

Connecting with a computer

Use the included USB cable to connect the unit to a computer USB port compatible with 2.0, 3.0 or higher USB specifications. When the USB connection is working, the USB indicator on the front of the unit lights.

ATTENTION

If you connect this unit to a computer via a USB hub, for example, bus power could be insufficient, and audio signal dropouts, clicking noises and other interference could occur due to the influence of other USB devices connected to that hub. For this reason, we strongly recommend connecting this unit to a separate USB port. Connecting USB keyboards and mice, however, to the same bus should not be a problem.

Connecting with iOS devices

To connect with an iOS device that has a Lightning connector use a Lightning to USB Camera Adapter* and the USB cable included with this product.

To connect with an iOS device that has a USB Type-C connector, use a commercially-available Type-C–Type-C cable.

* You must obtain a genuine Apple Lightning to USB Camera Adapter separately.

NOTE

- When connected, this unit will not provide power to the iOS device.
- To change unit settings, use the Settings Panel application installed on a Windows or Mac computer before connecting to the device.

Audio connections

Analog audio signals input into this device from mics, guitars, keyboards and other audio equipment can be converted into digital signals and transmitted to the computer via USB. In addition, by connecting speakers (through an amplifier if not powered) or headphones to this unit, you can monitor audio signals that are input to this unit and output from the computer.

CAUTION

Before connecting audio equipment, set the GAIN, LINE OUT and PHONES knobs to their lowest values. Failure to do so could cause sudden loud noises from monitoring equipment, and this could damage the equipment or harm hearing.

Connecting microphones

Dynamic mics

Connect these to the IN1 jack on the front of the unit.

Condenser mics

When using a condenser mic that requires phantom power, connect it to the IN1 jack on the front of the unit, and set the +48V switch to ON.

When the +48V switch is set to ON, the +48V indicator on the front of the unit lights.

CAUTION

Lower the LINE OUT and PHONES knobs before changing the phantom power switch between ON/OFF. Depending on the connected mics, sudden loud noises from monitoring equipment could occur, and this could damage the equipment or harm hearing.

ATTENTION

- Before connecting condenser mics, turn this unit and all equipment to be connected off (standby).
- Do not turn phantom power on when connecting a mic that does not require phantom power.
- Do not connect or disconnect mics while the phantom power switch is set to ON. Doing so could cause a loud noise and might damage this unit and connected equipment.
- Set the phantom power switch to ON only when using a condenser microphone that requires phantom power. Setting phantom power to ON when a dynamic mic or other equipment that does not require it is connected could damage this unit and the connected equipment.
- Supplying phantom power to some ribbon mics could break them. If you are unsure, do not supply phantom power to a ribbon mic.
- If you connect this unit to a laptop computer that is running on battery power and set the phantom power switch to +48V, the computer battery charge will be consumed more quickly.

Connecting guitars

When connecting a guitar or bass directly to this unit, use the IN2 jack on the front of the unit and set the LINE/INST switch to INST.

Connecting electronic instruments and other audio equipment

When connecting an electronic instrument or other audio equipment directly to this unit, use the IN2 jack on the front of the unit or the LINE IN L-R jacks on the back.

When connecting to the IN2 jack, set the INPUT SELECT switch to FRONT and the LINE/INST switch to LINE. When connecting to the LINE IN L-R jacks, set the INPUT SELECT switch to REAR.

Connecting analog record players

The output of an analog record player cannot be connected directly to this unit. To connect an analog record player to this unit, a phono amp and equalizer (or an audio amplifier that has phono input jacks) must be connected between them.

Connecting monitor speakers

Connect monitor speakers (powered speakers or an amplifier and speaker system) to the LINE OUT jacks on the back of the unit.

Use the LINE OUT knob on the front of the unit to adjust the speaker volume.

Connecting headphones

Connect headphones to the PHONES jack (standard stereo) on the front of the unit.

CAUTION

Before connecting headphones, minimize the volume with the PHONES knob. Failure to do so could result in a sudden loud noise that could harm hearing, for example.

Using direct monitoring

Setting the DIRECT MONITOR switch on the back of the unit to ON enables the Settings Panel Monitor Balance slider and input monitoring without delay (direct monitoring).

Use the Settings Panel Monitor Balance slider to adjust the monitoring balance between the signals from the input jacks and the signals output from the computer.

NOTE

- This setting adjusts the monitoring balance. It does not affect recording levels.
- When using this function, confirm that the input is not set as an output (monitoring on, for example) in the DAW or other recording software. Input signals could be added to computer output signals, resulting in the doubling of sounds.

5 – Using the Settings Panel

Opening the Settings Panel

You can use the Settings Panel to make settings for the various functions of this unit.

Open the Settings Panel in the following manner.

NOTE

- The unit will operate using the setting values set in the Windows or Mac Settings Panel.
- The Settings Panel cannot be used with an iPad or other iOS device.
- To change unit settings, use the Settings Panel application installed on a Windows or Mac computer.

Windows

- From the “Start” menu select “US_HR Settings Panel” under “TASCAM”.

Mac

- On the Launchpad, click “US-HR_SettingsPanel”.
- Using the Finder, open the Applications folder and click “US-HR_SettingsPanel” to open the Settings Panel.

Settings Panel overview

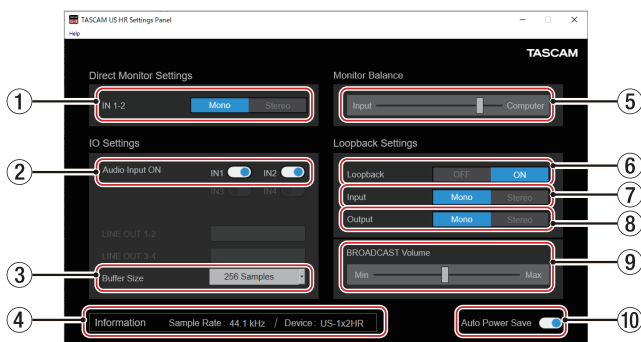

Windows Settings Panel



Mac Settings Panel

① IN 1-2 buttons

Set the monitoring signal for the IN1, IN2 and LINE IN L-R jacks to Mono or Stereo.

The selected **Mono** or **Stereo** button appears lit.

Button	Meaning
Mono	The signals output from the channels set for the Monitor Mix will be mono. Signals sent from the computer depend on the Loopback setting.
Stereo	The signals output from the channels set for the Monitor Mix will be stereo. Signals sent from the computer depend on the Loopback setting.

② Audio Input ON switches

Turn input on/off for each input separately.

When on, the switches will appear lit and signals will be input on those channels.

③ Buffer Size (Windows Only)

You can adjust the size of the buffer used to handle the audio input and output signals transferred to and from the computer.

Smaller buffer sizes result in less audio signal delay (latency), but require high-speed processing by the computer.

If the processing cannot keep up, for example, due to other system operations, clicking and popping noises might occur and the audio signal might even drop out.

Increasing the buffer size will stabilize operation and suppress negative effects on audio signals, but the delay in audio signals sent to the computer will increase.

You can adjust the buffer size used with this unit according to your use conditions.

Options

*4 Samples, 8 Samples, 16 Samples,
24 Samples, 32 Samples, 64 Samples,
128 Samples, 256 Samples (default), 512 Samples,
1024 Samples, 2048 Samples*

④ Information display area

This shows the current status of the unit.

Item displayed	Meaning
<i>Sample Rate</i>	This shows the sampling frequency.
<i>Device</i>	This is the name of the connected unit. (“No Device” is shown when no device is connected.)

⑤ Monitor Balance slider

When the DIRECT MONITOR switch on the back of the unit is ON, use this to adjust the monitoring balance between the input signals from the input jacks and the output signals from the computer. (see “Using direct monitoring” on page 11)

Moving the Monitor Balance slider toward the left (Input) increases the volume of signals from the unit’s input jacks and moving it toward the right (Computer) increases the volume of signals from the computer.

This setting adjusts the monitoring balance. It does not affect recording levels.

5 – Using the Settings Panel

⑥ Loopback

Use to turn the loopback function on or off. When off, the Input, Output and BROADCAST Volume settings are not applied.

Options: **OFF** (default), **ON**

ATTENTION

If using an application in which only one channel is input even though Loopback is set to “**Stereo**” (stereo input is not supported), “**Mono**” Loopback must be used. In this case, set both Input and Output to “**Mono**”.

⑦ Input

Use to set whether the input signal from the IN1/IN2 jack is converted to mono or kept as stereo when used as a loopback signal.

Options: **Mono**, **Stereo** (default)

⑧ Output

Use to set whether signals are converted to mono or kept as stereo when looping back USB output

Options: **Mono**, **Stereo** (default)

⑨ BROADCAST Volume slider

Use to adjust the playback volume of Sound Recorder and karaoke apps. Use this also to adjust the transmitted volume with live broadcast apps.

NOTE

When adjusting the BROADCAST Volume, set the Monitor Balance slider all the way to the right (Computer).

⑩ Auto Power Save ON switch

Turn this on to enable the automatic power saving function. When this setting is on, if operating in standalone mode and no input signal (above -60 dBFS) has been detected for 30 minutes, the unit will turn itself off (start standby) automatically.

Notification function

If the computer you are using is connected to the Internet, notifications might appear when the Settings Panel is launched.

NOTE

Put a check in the “*Do not show the same message again*” checkbox to prevent the same message from being shown the next time it is launched.

Checking software and firmware versions

Select About from the Help menu to open the following screen. The software and firmware versions can be checked here.



Item displayed	Meaning
Firmware Ver.	This is the firmware version used by the connected unit.
Software Ver.	This is the software version.

5 – Using the Settings Panel

Automatic software and firmware update function

If the computer you are using is connected to the Internet, when a new version of the software or the firmware is released, a notification about automatic updating will appear when the software is launched.

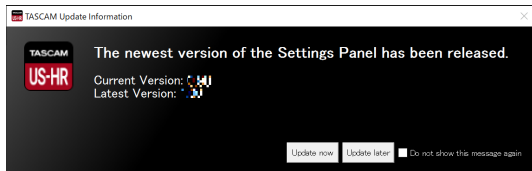

Software update notification

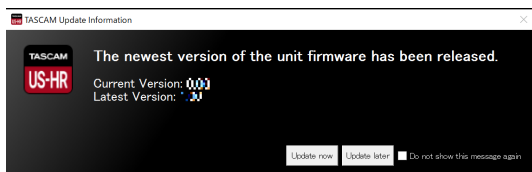

Firmware update notification

Click the **“Update now”** button to use the latest version of the software or firmware.

The file will be downloaded automatically in the update software will launch.

Click the **“Update later”** button to close the update window if you do not want to update or want to update later.

NOTE

- Put a check in the **“Do not show the same message again”** checkbox to prevent the same window from being shown the next time it is launched.
- After closing the update window, you can reopen it by selecting **“Update”** from the **“Help”** menu.

6 – Application Guide

In this chapter, we explain how to set some audio applications for use with this unit.

DAW software

Bundled DAW software

Download quickstart guides for the bundled DAW software from the TEAC Global Site (<https://teac-global.com/>), and refer to them for instructions about downloading, installing and making settings in these applications.

Other DAW software

When using any other DAW software, consult its operation manual.

When using a DAW that supports ASIO, select “US-HR Series ASIO”.

Windows

1. Open the “**Sound**” screen using the procedures for the operating system being used (Windows 10/Windows 8.1/Windows 7).
2. On the “**Playback**” page, right-click “**US-1x2 HR**”, and click “**Set as Default Device**” in the pop-up menu that appears. When you do this, the green check mark appears next to the selected device.

NOTE

To use the unit as a recording device, set the default device according to the device being used on the “**Recording**” tab in the same manner as on the “**Playback**” tab.

3. After completing the setting, click the “**OK**” button.
4. Start an audio application, select an audio file and begin playback.

NOTE

- If you change the setting while an audio application is running, the software will not recognize that the device has been changed. In this case, restart the application.
- If you still cannot hear sound after making the settings and completing the procedures above, restart the computer.
- If you make this setting, sound will be output through this unit, but no sound will be output from the computer’s speakers or headphone jack.

macOS

1. Open the “**Utilities**” folder in the “**Applications**” folder, and double-click “**Audio MIDI Setup**”. Then open the “**Audio Devices**” window.
2. Click “**US-1x2 HR**” to select it. Then, while right-clicking or control-clicking it, click “**Use this device for sound output**” in the pop-up menu that appears.
The speaker mark moves next to “**US-1x2 HR**”.

NOTE

To use this device as the recording device, set “**US-1x2 HR**” to “**Use this device for sound input**”.

3. Launch an audio application, select an audio file and start playback.

NOTE

- Do not change the sampling frequency when an audio application is playing back.
- If there is no need to change the sampling frequency, input/output device settings can also be made in the Sound pane of the System Preferences.

iOS

When using this unit with an iOS device, no special settings are necessary. You can use the unit immediately after connecting it to the device by USB.

NOTE

- Connecting headphones or other equipment to the headphone jack of the iOS device will interrupt USB communication with the unit.
- The unit will operate with the factory default settings or the settings as have been changed using a Windows/Mac computer.

Factory default settings for the unit

- Direct Monitor Settings: Mono
- Audio Input: ON
- Loopback: OFF
- Auto Power Save: ON

7 – Standalone Mode

Overview

- This unit will operate in standalone mode when it is turned on if it is not connected to a computer or iOS device by USB.
- You can use this unit as a mic preamp and to monitor input signals. This function is convenient when you want to practice an instrument without recording, for example.
- An external power supply device is necessary. See “Connecting the power” on page 9 for details.

Settings in standalone mode

When operating in standalone mode, input signals pass-through the built-in digital mixer and output selector, which are set at fixed values, and are output from the output jacks. In addition, when operating in standalone mode, the USB indicator will blink.

Settings Panel settings

The current (most recently made) settings are retained for the following items on the Settings Panel.

- *Direct Monitor Settings IN 1-2*
- *Auto Power Save*

8 – Troubleshooting

Please read this chapter if you are unable to use the unit properly even after setting it up following the procedures in this manual.

If you are still unable to resolve your problems please contact TASCAM customer support with the following information about the operating environment and details about the trouble.

Operating environment

- Computer manufacturer:
- Model:
- CPU:
- Memory (RAM):
- Operating system:
- Applications used:
- Antivirus software:
- Wireless LAN use:

If these measures do not resolve the issue, please contact the retailer where you purchased this unit or a TEAC service center. See the end of this document for contact information.

The dedicated software cannot be installed

1. Check the operating system
The operating system being used might not be compatible with the software that you are trying to install. Check the compatible operating system of the software you are trying to install again.
2. Stop software running in the background
Antivirus software and other software that runs in the background can prevent installation. Quit software that runs in the background and try installation again.

The unit is connected, but the computer does not recognize it

1. Install the dedicated software
 - If you have not done so, install the dedicated software. See “Installing the dedicated software” on page 6 for details.
2. Change the USB port
 - This unit cannot be used with USB 1.1. Use a port that supports at least USB 2.0 or USB 3.0.
 - Do not use a USB hub with this unit. Always connect the unit directly to a USB port on the computer.
 - If the above methods do not resolve the problem, connect the unit to a different USB port on the computer.

There is no sound even when playing back on the computer

Check the status of the unit’s connection with the computer. Moreover, if you make the following settings, sound will be output through this unit, but no sound will be output by the computer’s speakers or headphone jack.

Windows

See the “Windows” section of “6 – Application Guide” on page 15 in this manual, and make settings as necessary for the OS.

Mac

1. Quit all applications and open “*System Preferences...*” from the Apple menu.
2. Open “*Sound*”.
3. On the “*Output*” tab, select “*US-1x2 HR*”.

After completing the setting, restart the computer and check the sound of playback.

Depending on the application that you are using, you might need to make additional device settings.

In particular, DAW software operate using audio engines with settings that are different from the OS settings, so confirm the DAW settings first after installing the driver and Settings Panel software for this unit.

Please see the manuals for the applications that you are using for detailed setting procedures.

The input sound has too much latency when monitoring

Use the direct monitoring function. (see “Using direct monitoring” on page 11)

The input sound can be heard doubled

Confirm that the input is not set as an output (monitoring on, for example) in the DAW or other recording software.

An input signal from an input jack could sound doubled because along with direct monitoring it is also being monitored as an output signal from the computer.

8 – Troubleshooting

Sound breaks up or there is noise

The processing load on the computer causes sound to break up and noise to occur.

Here are some methods to reduce the load on the computer.

1. A wireless LAN and software running in the background, including antivirus software, regularly put processing loads on the computer, which can cause sound to break up and other noise.
Stop wireless LAN transmission, antivirus software and other software running in the background when using this unit.
2. Set the buffer size (latency) in the audio application that you are using or in this unit's Settings Panel to a larger value (Windows only).

NOTE

Consult the maker of the audio application that you are using for methods to reduce its load on your computer.

3. Change the settings of your computer so that they are optimal for audio processing.

Using Windows

- Performance Options
 - ① Open the Control Panel using the appropriate method for the OS you are using (Windows 10/Windows 8.1/Windows 7).
 - In Windows 10, open the “Control Panel”. Then, click the “System” icon.
 - In Windows 8.1, right-click the ordinary Start screen (Metro user interface screen) and then click “All apps”. Then, right-click “Computer” and select “Properties”.
 - In Windows 7, right-click “Computer” from the Windows Start button, and select “Properties”.
 - ② Click “Advanced system settings”.
 - ③ Click “Settings” in the “Performance” section of the “Advanced” tab of the “System Properties” window.
 - ④ In the “Visual Effects” tab of the “Performance Options” window, select “Adjust for best performance”.
- Power Options
 - ① Open the Control Panel using the appropriate method for the OS you are using (Windows 10/Windows 8.1/Windows 7).
 - ② Click “Hardware and Sound”.
 - ③ Click “Power Options”.
 - ④ Click on “Create a power plan” and select “High Performance”.

NOTE

If an item is not shown, select the “Show Additional Plans” downward triangular button. Alternatively, click “Create a power plan”.

Using Mac

- ① Open “System Preferences...” from the Apple menu, and select “Energy Saver”.
- ② Set “Computer sleep” to “Never”.
- ③ Set “Display sleep” to “Never”.

NOTE

Depending on the macOS version and Mac computer model, this setting might not be available.

4. Connect to a different USB port.
Since the unit might not properly function with some USB ports, try connecting it to a different USB port.

NOTE

- Try again after disconnecting other USB devices (Keyboards and mice can be left connected).
- Do not use a USB hub. Always connect the unit directly to a USB port on the computer (built-in).

I see that the US-1x2HR recommends that I change the Windows Power Management settings. How do I do this?

Windows allows the processor to throttle to half speed when the computer is idle. However, this can affect the performance of DAW recording software.

To Change the Power Management settings in Windows:

1. Open the Control Panel using the appropriate method for the OS you are using (Windows 10/Windows 8.1/Windows 7).
2. Click “Hardware and Sound”.
3. Click “Power Options”.
4. Select “High Performance” from the “Power Options”.

NOTE

If an item is not shown, select the “Show Additional Plans” downward triangular button. Alternatively, click “Create a power plan”.

Support for bundled software, including DAW software

TASCAM does not provide end-user support for the bundled DAW Software.

Please check the Help menu of the installed software to find where this support is available.

General

Sampling frequencies

44.1, 48, 88.2, 96, 176.4, 192 kHz

Quantization bit depth

24-bit

Input/output ratings

Analog inputs

IN1 input

Mic input (Balanced)

Connector: XLR-3-31 equivalent (1: GND, 2: HOT, 3: COLD)

Maximum input level: +9 dBu (2.183 Vrms)

Rated input level: -7 dBu (0.346 Vrms)

Gain range: 56 dB

Input impedance: 2.4 k Ω

IN2 input

LINE input (Balanced)

(LINE/INST switch set to LINE)

Connector: 6.3mm (1/4") standard TRS jack
(Tip: HOT, Ring: COLD, Sleeve: GND)

Maximum input level: +20 dBu (7.750 Vrms)

Rated input level: +4 dBu (1.228 Vrms)

Gain range: 45dB

Input impedance: 10 k Ω

INST input (Unbalanced)

(LINE/INST switch set to INST)

Connectors: 6.3mm (1/4") standard TS jacks
(Tip: HOT, Sleeve: GND)

Maximum input level: +3 dBV (1.413 Vrms)

Rated input level: -13 dBV (0.224 Vrms)

Gain range: 45dB

Input impedance: 1 M Ω or more

LINE L/R inputs (Unbalanced)

Connectors: RCA pin jacks

Maximum input level: +6 dBV (1.995 Vrms)

Rated input level: -10 dBV (0.316 Vrms)

Input impedance: 10 k Ω

Analog outputs

LINE OUT L-R outputs (Unbalanced)

Connectors: RCA pin jacks

Maximum output level: +6 dBV (1.995 Vrms)

Rated output level: -10 dBV (0.316 Vrms)

Output impedance: 100 Ω

Headphones output (PHONES)

Connector: 6.3mm (1/4") standard stereo jack

Maximum output: 18mW + 18mW or higher
(THD+N 0.1% or less, into 32 Ω load)

Control input/output ratings

USB

Connector: 4-pin USB Type-C

Transfer rate: USB 2.0 High Speed (480 Mbps)

DC IN 5V

Connector: USB Micro B type

Audio performance

Mic preamp EIN (equivalent input noise)

-128 dBu or less

(150 Ω termination, GAIN knob at maximum, 20 kHz SPCL LPF+A-Weight)

Frequency response

MIC IN (IN1)

At 44.1/48 kHz, 20 Hz - 20 kHz: +0 dB/-0.4 dB (JEITA)

At 88.2/96 kHz, 20 Hz - 40 kHz: +0 dB/-0.4 dB (JEITA)

LINE IN (IN2)

At 44.1/48 kHz, 20 Hz - 20 kHz: +0 dB/-0.3 dB (JEITA)

At 88.2/96 kHz, 20 Hz - 40 kHz: +0 dB/-0.3 dB (JEITA)

LINE OUT

At 44.1/48 kHz, 20 Hz - 20 kHz: +0.2 dB/-0.4 dB (JEITA)

At 88.2/96 kHz, 20 Hz - 40 kHz: +0.2 dB/-0.4 dB (JEITA)

S/N ratio

109 dB

(MIC IN, GAIN knob at minimum, 20 kHz SPCL LPF+A-Weight)

105 dB

(LINE IN, GAIN knob at minimum, 20 kHz SPCL LPF+A-Weight)

110 dB

(LINE OUT, LINE OUT knob at maximum, 20 kHz SPCL LPF+A-Weight)

THD + N

0.0013%

(MIC IN, 1 kHz sine wave, -5 dBFS input, GAIN knob at minimum, 20 kHz SPCL LPF)

0.0027%

(LINE IN, 1 kHz sine wave, -5 dBFS input, GAIN knob at minimum, 20 kHz SPCL LPF)

0.0015%

(LINE OUT, 1 kHz sine wave, -4 dBFS input, LINE OUT knob at maximum, 20 kHz SPCL LPF)

Crosstalk

95 dB or more

(MIC/LINE IN to LINE OUT, 1 kHz sine wave, GAIN knob at minimum)

9 – Specifications

Computer system requirements

Check the TEAC Global Site (<https://teac-global.com/>) for the latest information about supported operating systems.

Windows

Supported operating systems

- Windows 10 32-bit
- Windows 10 64-bit
- Windows 8.1 32-bit
- Windows 8.1 64-bit
- Windows 7*
 - Windows 7 32-bit SP1 or later
 - Windows 7 64-bit SP1 or later

* Operation has been confirmed with the final version of Windows 7.

Computer hardware requirements

Windows computer with a USB 2.0 (or higher) port

CPU/processor speed

2 GHz or faster dual core processor (x86)

Memory

2 GB or more

ATTENTION

Operation of this unit was confirmed using standard computers that meet the above requirements. This does not guarantee operation with all computers that meet the above requirements. Even computers that meet the same system requirements might have processing capabilities that differ according to their settings and other operating conditions.

Mac

Supported operating systems

- macOS Catalina (10.15 or later)
- macOS Mojave (10.14 or later)
- macOS High Sierra (10.13 or later)

Computer hardware requirements

Mac with a USB 2.0 (or higher) port

CPU/processor speed

2 GHz or faster dual core processor

Memory

2 GB or more

iOS device

Operation has been confirmed with Apple devices running the following iOS versions.

- iPadOS13
- iOS13
- iOS12
- iOS11

ATTENTION

To connect an iOS device that has a Lightning connector, a genuine Apple Lightning to USB Camera Adapter (sold separately) is necessary.

Supported audio drivers

Windows

ASIO2.0, WDM

Mac

Core Audio

iOS device

Core Audio

Other

Power

Used with a computer

USB bus power

Used with an iOS device

USB power adapter (that can supply 5 V and a current of at least 700 mA)(*1)

External battery pack (that can supply 5 V and a current of at least 700 mA)(*2)

*1 We strongly recommend using TASCAM PS-P520E AC adapter or the USB power adapter included with the iPad/iPhone. No USB power adapter is included with an iPod touch. To use it with an iPod touch, purchase a genuine Apple USB power adapter (that can supply 5 V and a current of at least 700 mA) separately.

*2 We strongly recommend using a TASCAM BP-6AA external battery pack. If using another external battery pack or mobile battery, purchase one that can supply 5 V and a current of at least 700 mA.

Power consumption

1.8W

Dimensions

146 × 55 × 120 mm (W x H x D, including protrusions)

Weight

623 g

Operating temperature range

5–35 °C (41 - 95°F)

Dimensional drawings

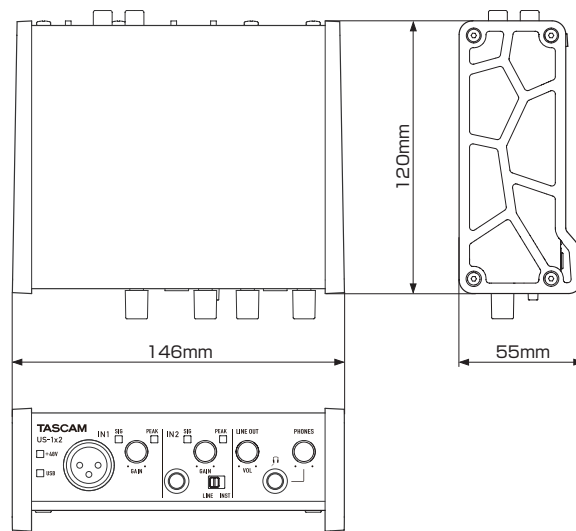

- Illustrations in this manual might differ in part from the actual product.
- Specifications and external appearance might be changed without notification to improve the product.

Block diagram

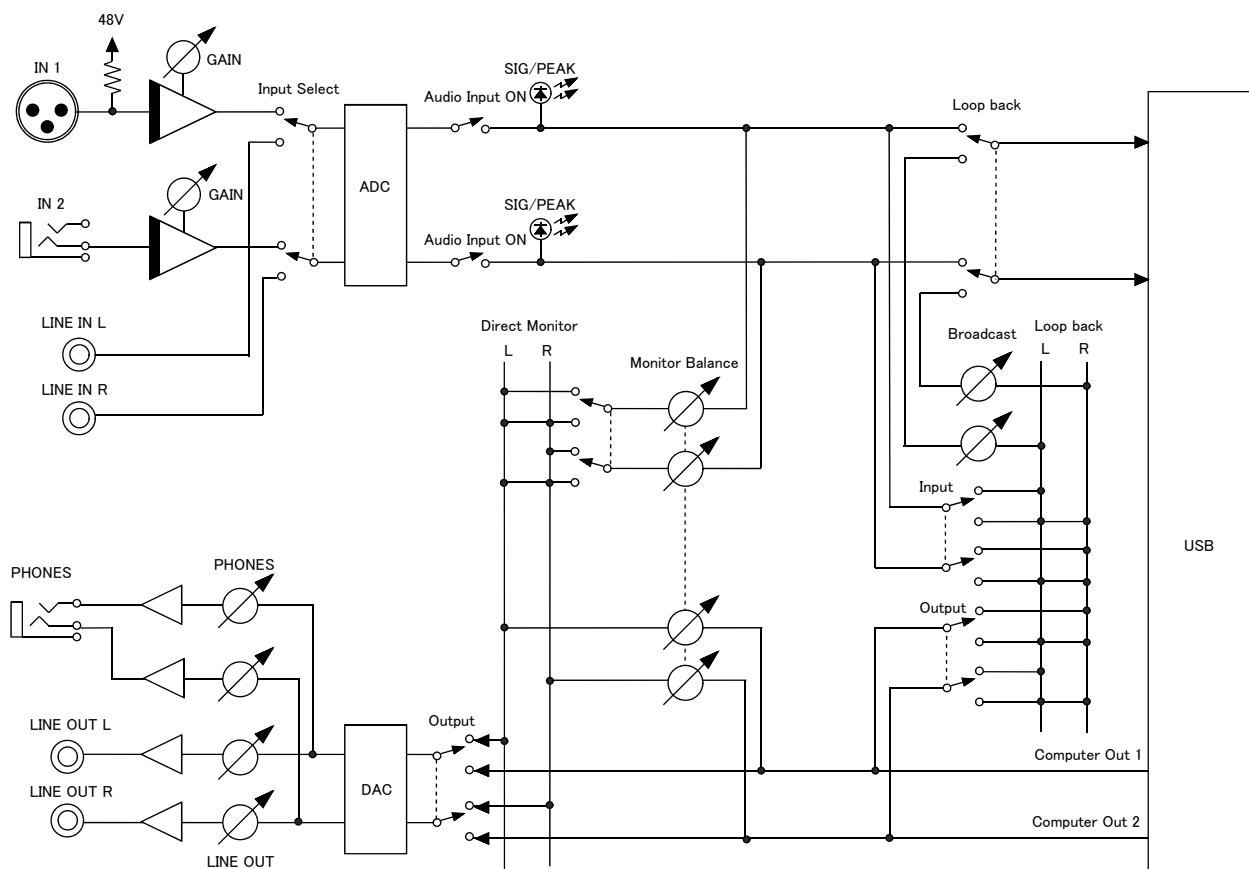

TASCAM

TEAC CORPORATION

Phone: +81-42-356-9143

1-47 Ochiai, Tama-shi, Tokyo 206-8530 Japan

<https://tascam.jp/jp/>

TEAC AMERICA, INC.

Phone: +1-323-726-0303

10410 Pioneer Blvd. Suite #1 Santa Fe Springs, California 90670, U.S.A.

<https://tascam.com/us/>

TEAC UK Ltd.

Phone: +44-1923-797205

Luminous House, 300 South Row, Milton Keynes, Buckinghamshire, MK9 2FR, UK

<https://www.tascam.eu/en/>

TEAC EUROPE GmbH

Phone: +49-611-71580

Bahnstrasse 12, 65205 Wiesbaden-Erbenheim, Germany

<https://www.tascam.eu/de/>

TEAC SALES & TRADING(SHENZHEN) CO., LTD

Phone: +86-755-88311561~2

Room 817, Xinian Center A, Tairan Nine Road West, Shennan Road, Futian District, Shenzhen, Guangdong Province 518040, China

<https://tascam.cn/cn/>

0121. MA-3214B