

TASCAM

TEAC Professional Division

D00680501B

CD-D1x4

CD Duplicator

Professional

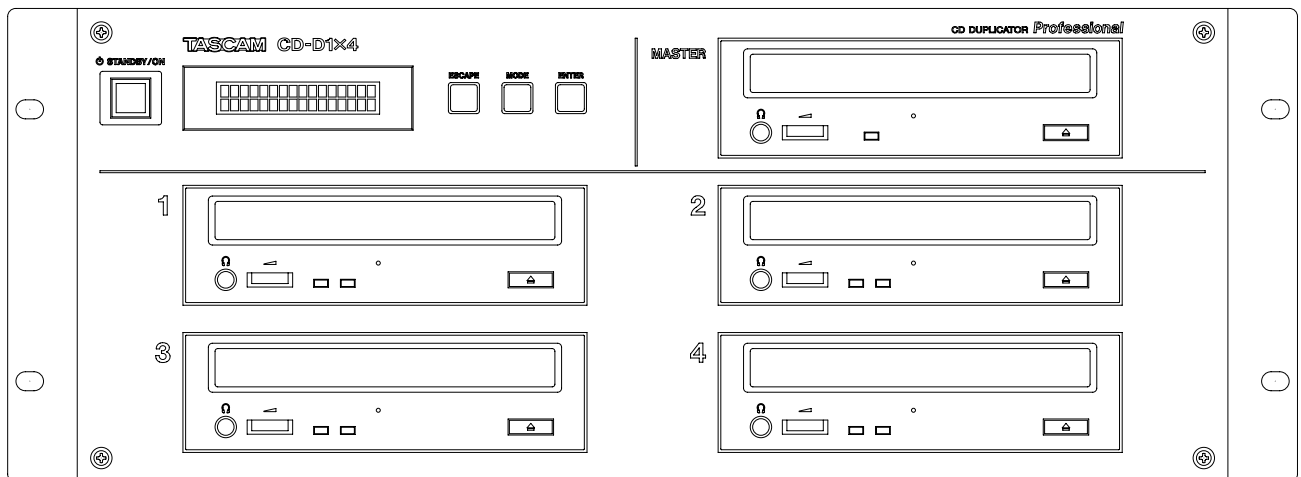

OWNER'S MANUAL



CAUTION
RISK OF ELECTRIC SHOCK
DO NOT OPEN



CAUTION: TO REDUCE THE RISK OF ELECTRIC SHOCK, DO NOT REMOVE COVER (OR BACK). NO USER-SERVICEABLE PARTS INSIDE. REFER SERVICING TO QUALIFIED SERVICE PERSONNEL.



The lightning flash with arrowhead symbol, within an equilateral triangle, is intended to alert the user to the presence of uninsulated "dangerous voltage" within the product's enclosure that may be of sufficient magnitude to constitute a risk of electric shock to persons.



The exclamation point within an equilateral triangle is intended to alert the user to the presence of important operating and maintenance (servicing) instructions in the literature accompanying the appliance.

This appliance has a serial number located on the rear panel. Please record the model number and serial number and retain them for your records.

Model number _____
Serial number _____

WARNING: TO PREVENT FIRE OR SHOCK HAZARD, DO NOT EXPOSE THIS APPLIANCE TO RAIN OR MOISTURE.

Important Safety Precautions

IMPORTANT (for U.K. Customers)

DO NOT cut off the mains plug from this equipment.

If the plug fitted is not suitable for the power points in your home or the cable is too short to reach a power point, then obtain an appropriate safety approved extension lead or consult your dealer.

If nonetheless the mains plug is cut off, remove the fuse and dispose of the plug immediately, to avoid a possible shock hazard by inadvertent connection to the mains supply.

If this product is not provided with a mains plug, or one has to be fitted, then follow the instructions given below:

IMPORTANT: The wires in this mains lead are coloured in accordance with the following code:

GREEN-AND-YELLOW	: EARTH
BLUE	: NEUTRAL
BROWN	: LIVE

WARNING: This apparatus must be earthed.

As the colours of the wires in the mains lead of this apparatus may not correspond with the coloured markings identifying the terminals in your plug proceed as follows:

The wire which is coloured GREEN-and-YELLOW must be connected to the terminal in the plug which is marked by the letter E or by the safety earth symbol \equiv or coloured GREEN or GREEN-and-YELLOW.

The wire which is coloured BLUE must be connected to the terminal which is marked with the letter N or coloured BLACK.

The wire which is coloured BROWN must be connected to the terminal which is marked with the letter L or coloured RED.

When replacing the fuse only a correctly rated approved type should be used and be sure to re-fit the fuse cover.

IF IN DOUBT — CONSULT A COMPETENT ELECTRICIAN.

For U.S.A

TO THE USER

This equipment has been tested and found to comply with the limits for a Class A digital device, pursuant to Part 15 of the FCC Rules. These limits are designed to provide reasonable protection against harmful interference when the equipment is operated in a commercial environment. This equipment generates, uses, and can radiate radio frequency energy and, if not installed and used in accordance with the instruction manual, may cause harmful interference to radio communications.

Operation of this equipment in a residential area is likely to cause harmful interference in which case the user will be required to correct the interference at his own expense.

CAUTION

Changes or modifications to this equipment not expressly approved by TEAC CORPORATION for compliance could void the user's authority to operate this equipment.

For the consumers in Europe

WARNING

This is a Class A product. In a domestic environment, this product may cause radio interference in which case the user may be required to take adequate measures.

Pour les utilisateurs en Europe

AVERTISSEMENT

Il s'agit d'un produit de Classe A. Dans un environnement domestique, cet appareil peut provoquer des interférences radio, dans ce cas l'utilisateur peut être amené à prendre des mesures appropriées.

Für Kunden in Europa

Warnung

Dies ist eine Einrichtung, welche die Funk-Entstörung nach Klasse A besitzt. Diese Einrichtung kann im Wohnbereich Funkstörungen verursachen ; in diesem Fall kann vom Betreiber verlangt werden, angemessene Maßnahmen durchzuführen und dafür aufzukommen.

The equipment draws nominal non-operating power from the AC outlet with its POWER switch in the off position.

IMPORTANT SAFETY INSTRUCTIONS

CAUTION:

- Read all of these Instructions.
- Save these Instructions for later use.
- Follow all Warnings and Instructions marked on the audio equipment.

- 1) Read Instructions** — All the safety and operating instructions should be read before the product is operated.
- 2) Retain Instructions** — The safety and operating instructions should be retained for future reference.
- 3) Heed Warnings** — All warnings on the product and in the operating instructions should be adhered to.
- 4) Follow Instructions** — All operating and use instructions should be followed.
- 5) Cleaning** — Unplug this product from the wall outlet before cleaning. Do not use liquid cleaners or aerosol cleaners. Use a damp cloth for cleaning.
- 6) Attachments** — Do not use attachments not recommended by the product manufacturer as they may cause hazards.
- 7) Water and Moisture** — Do not use this product near water — for example, near a bath tub, wash bowl, kitchen sink, or laundry tub; in a wet basement; or near a swimming pool; and the like.
- 8) Accessories** — Do not place this product on an unstable cart, stand, tripod, bracket, or table. The product may fall, causing serious injury to a child or adult, and serious damage to the product. Use only with a cart, stand, tripod, bracket, or table recommended by the manufacturer, or sold with the product. Any mounting of the product should follow the manufacturer's instructions, and should use a mounting accessory recommended by the manufacturer.
- 9)** A product and cart combination should be moved with care. Quick stops, excessive force, and uneven surfaces may cause the product and cart combination to overturn.



- 10) Ventilation** — Slots and openings in the cabinet are provided for ventilation and to ensure reliable operation of the product and to protect it from overheating, and these openings must not be blocked or covered. The openings should never be blocked by placing the product on a bed, sofa, rug, or other similar surface. This product should not be placed in a built-in installation such as a bookcase or rack unless proper ventilation is provided or the manufacturer's instructions have been adhered to.
- 11) Power Sources** — This product should be operated only from the type of power source indicated on the marking label. If you are not sure of the type of power supply to your home, consult your product dealer or local power company. For products intended to operate from battery power, or other sources, refer to the operating instructions.
- 12) Grounding or Polarization** — This product may be equipped with a polarized alternating-current line plug (a plug having one blade wider than the other). This plug will fit into the power outlet only one way. This is a safety feature. If you are unable to insert the plug fully into the outlet, try reversing the plug. If the plug should still fail to fit, contact your electrician to replace your obsolete outlet. Do not defeat the safety purpose of the polarized plug.
- 13) Power-Cord Protection** — Power-supply cords should be routed so that they are not likely to be walked on or pinched by items placed upon or against them, paying particular attention to cords at plugs, convenience receptacles, and the point where they exit from the product.
- 14) Outdoor Antenna Grounding** — If an outside antenna or cable system is connected to the product, be sure the antenna or cable system is grounded so as to provide some protection against voltage surges and built-up static charges. Article 810 of the National Electrical Code, ANSI/NFPA 70, provides information with regard to proper grounding of the mast and supporting structure, grounding of the lead-in wire to an antenna discharge unit, size of grounding conductors, location of antenna-discharge unit, connection to grounding electrodes, and requirements for the grounding electrode.

"Note to CATV system installer:

This reminder is provided to call the CATV system installer's attention to Section 820-40 of the NEC which provides guidelines for proper grounding and, in particular, specifies that the cable ground shall be connected to the grounding system of the building, as close to the point of cable entry as practical.

Example of Antenna Grounding as per National Electrical Code, ANSI/NFPA 70

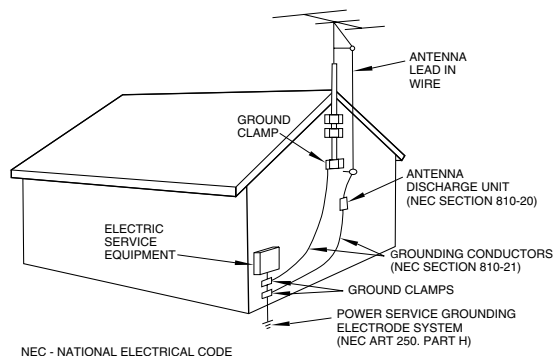

- 15) Lightning** — For added protection for this product during a lightning storm, or when it is left unattended and unused for long periods of time, unplug it from the wall outlet and disconnect the antenna or cable system. This will prevent damage to the product due to lightning and power-line surges.
- 16) Power Lines** — An outside antenna system should not be located in the vicinity of overhead power lines or other electric light or power circuits, or where it can fall into such power lines or circuits. When installing an outside antenna system, extreme care should be taken to keep from touching such power lines or circuits as contact with them might be fatal.
- 17) Overloading** — Do not overload wall outlets, extension cords, or integral convenience receptacles as this can result in risk of fire or electric shock.
- 18) Object and Liquid Entry** — Never push objects of any kind into this product through openings as they may touch dangerous voltage points or short-out parts that could result in a fire or electric shock. Never spill liquid of any kind on the product.
- 19) Servicing** — Do not attempt to service this product yourself as opening or removing covers may expose you to dangerous voltage or other hazards. Refer all servicing to qualified service personnel.
- 20) Damage Requiring Service** — Unplug this product from the wall outlet and refer servicing to qualified service personnel under the following conditions:
 - a) when the power-supply cord or plug is damaged.
 - b) if liquid has been spilled, or objects have fallen into the product.
 - c) if the product has been exposed to rain or water.
 - d) if the product does not operate normally by following the operating instructions. Adjust only those controls that are covered by the operating instructions as an improper adjustment of other controls may result in damage and will often require extensive work by a qualified technician to restore the product to its normal operation.
 - e) if the product has been dropped or damaged in any way.
 - f) when the product exhibits a distinct change in performance — this indicates a need for service.
- 21) Replacement Parts** — When replacement parts are required, be sure the service technician has used replacement parts specified by the manufacturer or have the same characteristics as the original part. Unauthorized substitutions may result in fire, electric shock, or other hazards.
- 22) Safety Check** — Upon completion of any service or repairs to this product, ask the service technician to perform safety checks to determine that the product is in proper operating condition.
- 23) Wall or Ceiling Mounting** — The product should be mounted to a wall or ceiling only as recommended by the manufacturer.
- 24) Heat** — The product should be situated away from heat sources such as radiators, heat registers, stoves, or other products (including amplifiers) that produce heat.

SAFETY INFORMATION

This product has been designed and manufactured according to FDA regulations "title 21, CFR, chapter 1, subchapter J, based on the Radiation Control for Health and Safety Act of 1968", and is classified as a class 1 laser product. There is no hazardous invisible laser radiation during operation because invisible laser radiation emitted inside of this product is completely confined in the protective housings.

The label required in this regulation is shown in ①.

CAUTION

- DO NOT REMOVE THE PROTECTIVE HOUSING USING A SCREWDRIVER.
- USE OF CONTROLS OR ADJUSTMENTS OR PERFORMANCE OF PROCEDURES OTHER THAN THOSE SPECIFIED HEREIN MAY RESULT IN HAZARDOUS RADIATION EXPOSURE.
- IF YOU SHOULD EXPERIENCE ANY PROBLEMS WITH THIS PRODUCT THAT CANNOT BE RESOLVED WITH THE "TROUBLE-SHOOTING" SECTION LATER IN THIS MANUAL, CONTACT A TEAC AUTHORIZED SERVICE AGENCY. DO NOT CONTINUE TO USE THE PRODUCT UNTIL THE PROBLEM IS RESOLVED.

Optical pickup (MASTER):	Type:	PXR-550X
	Manufacturer:	MITSUMI Electric Co., Ltd.
Optical pickups (slave):	Laser output:	Less than 0.1 mW (play) on the objective lens
	Wavelength:	777 - 787 nm
	Type:	SF-W03YTC
	Manufacturer:	SANYO Electric Co., Ltd.
	Laser output:	Less than 2.0 mY (play) and 37mW (record) on the objective lens
	Wavelength:	780 - 786 nm

- ② THIS LABEL IS ATTACHED TO THE PLACE AS ILLUSTRATED TO INFORM THAT THE APPARATUS CONTAINS A LASER COMPONENT.
- ② DIESE AUFKLEBEMARKE IST AN DEM IN DER ABBILDUNG GEZEIGTEN ORT ANGEBRACHT UM DARAUF HINZUWEISEN, DASS IM INNERN DES GERATS EINE LASER-KOMPONENTE BEFINDET.
- ② PASKRIFTEN SITTER PA APPARATEN SOM VISAS SOM UPPMANING OM ATT APPARATEN OMFATTAR EN INBYGGD LASERKOMPONENT.
- ② DETTE MARKAT ER ANBRAGT SOM VIST I ILLUSTRATIONEN FOR AT ADVARE BRUGEREN OM AT APPARATET INDEHOLDER EN



For U.S.A.

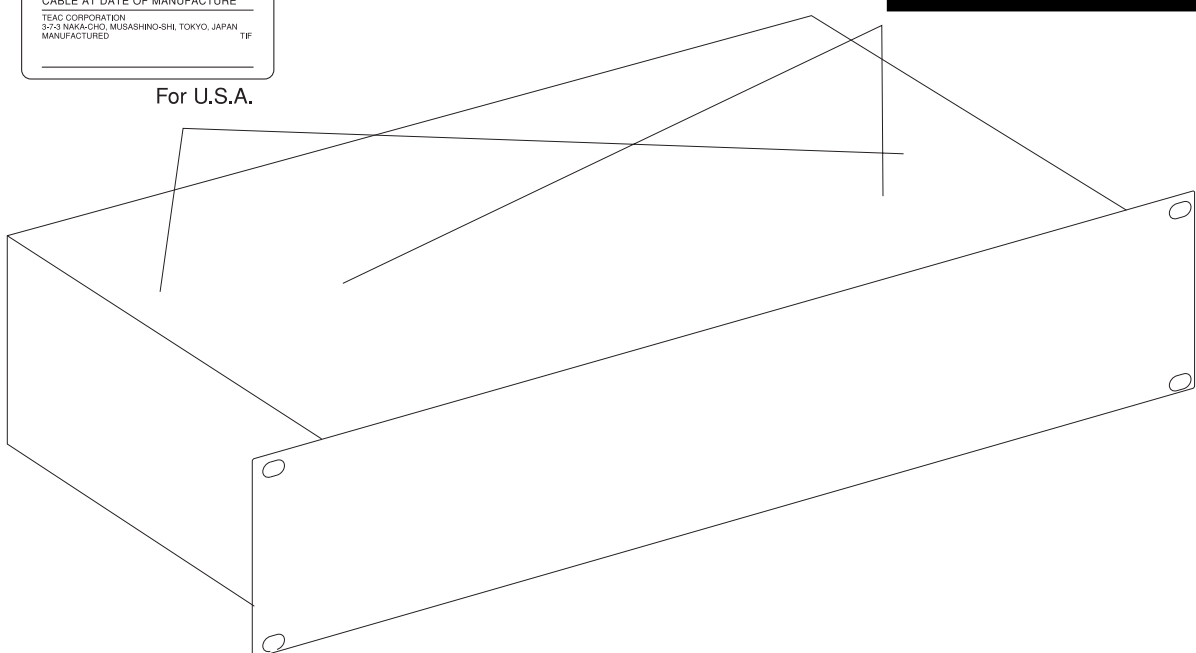
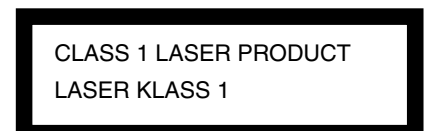

1 – Introduction	
About CD-R and CD-RW discs.....	7
Recordable media	7
Installing the CD-D1x4	7
Temperature considerations	7
2 – Parts of the CD-D1x4	
Front panel.....	8
Rear panel	9
3 – Care of recordable media	
Discs recommended for use with the CD-D1x4	10
4 – Basic operations	
Power-up procedure	11
Inserting discs	11
Power down	11
Modes.....	11
Finalized discs	11
Additional copy modes	12
5 – Disc copy	
Setting the writing speed.....	13
Copying the disc	14
6 – Simulation	
7 – Other functions	
Track extraction.....	16
Copy-protection.....	17
Audio playback.....	17
Erasing discs.....	18
Finding out about your CD-D1x4	18
Finding out the main unit version number...18	
The Session Mode option	19
Cascading	19
8 – Error messages and troubleshooting	
To clear an error.....	20
Error messages	20
9 – Specifications	
Operational specifications	21
Physical specifications	21
Dimensional drawing.....	21

1 – Introduction

The TASCAM CD-D1x4 CD duplicator provides you with a quick and simple method of copying your original audio material in CD format on up to four drives at once at considerably more than real-time speeds (up to 16 times), using easily-obtainable, low-cost CD-R or CD-RW media, with no auxiliary equipment or computer system required.

Another CD-D1x4 may be slaved to the first in order to provide an eight-drive unit (see “Cascading” on page 19).

It is especially useful for duplicating material produced using TASCAM CD-RW recorders on CD-RW media, which may be unplayable on certain types of CD player. The CD-D1x4 can read CD-RW discs produced on CD-RW recorders for easy duplication.

Copying can be performed on a disc-at-once basis (DAO) when the CD-D1x4 copies or performs track extraction operations on an audio disc, and on a track-at-once (TAO) basis for other discs.

The CD-D1x4 should only be used to duplicate CD-ROM material to which you own copyright or for which you have appropriate permission.

NOTE

This product is designed to help you record and reproduce sound works to which you own the copyright, or where you have obtained permission from the copyright owner or the rightful licensor. Unless you own the copyright, or have obtained the appropriate permission from the copyright owner or the rightful licensor, your unauthorized recording, reproduction or distribution thereof, may result in severe civil and criminal penalties under copyright laws and international copyright treaties. If you are uncertain about your rights, contact your legal advisor. Under no circumstances will TEAC Corporation be responsible for the consequences of any illegal copying performed using the CD-D1x4.

Depending on the quality of the source CD (audio CD, CD-R, CD-RW or CD-ROM), it is possible to copy material at up to sixteen times the real-time rate (selectable from the front panel), making it convenient for rapid duplication of a number of identical discs, etc.

Depending on the content of the source CD, you may not be able to read it, or to make a completely accurate copy of the source.

Making copies of copies of the same disc may degrade the sound quality. Always try to duplicate from an original disc, whenever possible.

NOTE

Although the operation of the CD-D1x4 is relatively straightforward, we strongly suggest that you read this manual before starting operations. There are a few factors affecting the production of CD-R discs using the CD-D1x4 which may not be immediately obvious.

1 – Introduction

About CD-R and CD-RW discs.....6

Recordable media6

Installing the CD-D1x4..... 6

Temperature considerations6

2 – Parts of the CD-D1x4

Front panel 7

Rear panel 8

3 – Care of recordable media

Discs recommended for use with the

CD-D1x4..... 9

4 – Basic operations

Power-up procedure..... 10

Inserting discs 10

Power down..... 10

Modes 10

Finalized discs 10

Additional copy modes 11

5 – Disc copy

Setting the writing speed 12

Copying the disc 13

6 – Simulation

7 – Other functions

Track extraction 15

Copy-protection 16

Audio playback 16

Erasing discs 17

Finding out about your CD-D1x4..... 17

Finding out the main unit version number...17

The Session Mode option..... 18

Cascading 18

8 – Error messages and troubleshooting

To clear an error..... 19

Error messages 19

9 – Specifications

Operational specifications 20

Physical specifications 20

Dimensional drawing 20

About CD-R and CD-RW discs

The CD-D1x4 uses CD-R and CD-RW media, and can also use CD-R and CD-RW Digital Audio media.

In this manual, when we refer to “CD-R” and CD-RW” discs, we always include “CD-R Digital Audio” and “CD-RW Digital Audio”, even when this is not explicitly stated.

CD-R discs can be recorded once only. Once they have been used for recording, they cannot be erased or re-recorded. However, if space is available on the disc, additional material may be recorded. The packaging of CD-R discs will include one of the following logos:



By contrast, a CD-RW disc can be used in much the same way as a CD-R disc, but the disc can be erased, and the disc can then be re-used for other recordings.

The packaging of CD-RW discs will include one of the following logos:



High-speed RW discs may be recorded at a higher speed than the usual high-speed discs. These will be marked on the packaging with a special logo:



However, you should note that an audio CD created using a CD-RW disc may not play back satisfactorily on every audio CD player. This is in no way a limitation of the CD-D1x4 itself, but of the difference between the different types of media and the methods used to read them.

CD-R discs created on the CD-D1x4, by contrast, may be played satisfactorily on the majority of audio CD players.

Recordable media

When a CD-R disc has been written, no more data can be written to it, and it is fixed, but when a CD-RW disc has been written, it can be erased and reused.

Note that the CD-D1x4 may not be able to use CD-RW media that have been erased by other models of

CD recorder. We recommend that you erase such media in the CD-D1x4 before use. Also note that you may have to wait some time after loading before such media are recognized by the CD-D1x4 (the drive indicator goes out).

Installing the CD-D1x4

The CD-D1x4 is designed to fit into 4U of standard 19” rack space. We suggest that you leave 1U of space above the unit to allow for cooling.

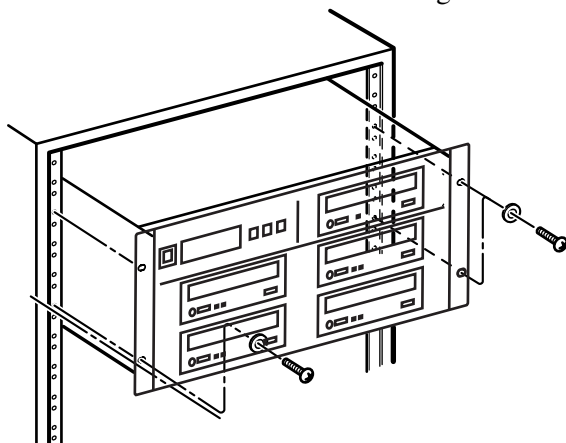

There are no connections to be made to and from the CD-D1x4 other than the power connection on the rear panel, as the unit is completely self-contained.

However, you can use the supplied cable to link two CD-D1x4 units together, and set one as the master unit, and one as the slave. This setting is made using the rear panel switch.

Leave 1U of space above each unit in a rack to allow for cooling.

Temperature considerations The ambient operating temperature should be between 5°C and 35°C (41°F and 95°F).

2 – Parts of the CD-D1x4

Front panel

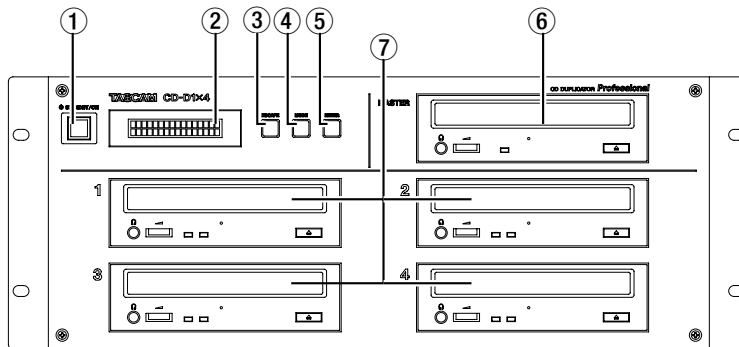

① **STANDBY/ON switch** Press this switch once to power on the unit, and again to turn it to standby mode. There is also a power switch on the rear panel which must be switched on first.

NOTE

If the unit does not turn on when you turn the front panel switch on, make sure the switch at the rear of the unit is also turned on.

② **Display** The 2 x 16 LCD display displays the menus and sub-menus available, and also provides information on the status of the current operation, as well as displaying error messages, etc.

③ **ESCAPE key** The **ESCAPE** key is used to go “up” a menu level or to cancel operations. A double “beep” is often produced when the **ESCAPE** key is pressed.

④ **MODE key** The **MODE** key is used to cycle through the different menus and options available to put the unit into the different modes, as explained below.

⑤ **ENTER key** The **ENTER** key is used to confirm the selection of menu items and options. It also acts as a “start” key to start operations.

⑥ **MASTER drive** The **MASTER** drive is used to hold the source CD. This may be a pre-recorded audio CD or CD-ROM which you have permission to copy, a CD-R or a CD-RW disc.

The eject button is used to eject the master disc when no operation is in progress. The indicator on this drive shows when the disc is being accessed.

In the “Play audio” mode (see “Audio playback” on page 17), a pre-recorded CD may be inserted into this drive, and played back, track by track. The headphone jack and volume controls of this drive are operational in this mode only.

⑦ **Slave drives (1, 2, 3, 4)** The slave drives hold the target discs.

The eject buttons are used to eject the target disc when no operation is in progress. The right indicator on these drives shows when the disc is being accessed for reading and the left indicator shows when the disc is being accessed for writing.

In the “Play audio” mode (see “Audio playback” on page 17), an audio CD may be inserted into one of these drives, and played back. The headphone jack and volume controls of this drive are operational in this mode only. We suggest that to avoid tangling the cord of the headphones in the drive door when it opens (automatically in many cases), you only plug in headphones when using the audio playback mode.

NOTE

If a disc is in a drive and cannot be removed by using the eject button, you can insert a thin stiff wire (such as the end of a paperclip) into the hole on the front panel of the drive (under the tray) when the unit is turned off. This will open the tray.

Rear panel

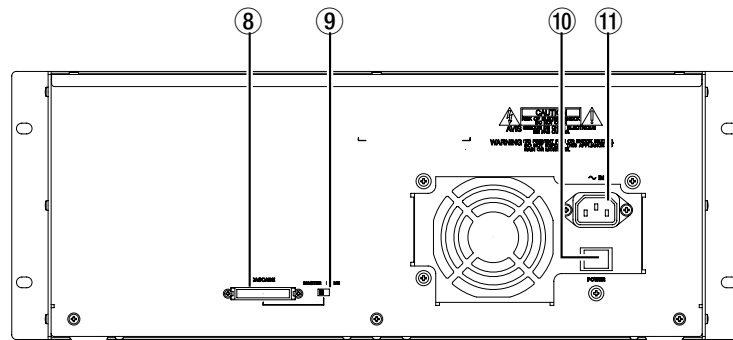

⑧ **CASCADE connector** Only use the cable supplied with the CD-D1x4 to connect two units. Make all connections with both power switches on both units turned off.

See “Cascading” on page 19 for details of how to operate units in a cascade.

⑨ **MASTER/SLAVE switch** Use this switch to determine which is the master and which is the slave unit when two units are connected using the **CASCADE** connectors.

⑩ **POWER switch** Like many personal computers, the CD-D1x4 has two power switches, one at the rear of the unit and one at the back. Make sure that this switch is on before turning on the front panel switch.

⑪ **~ IN (power input)** Connect the supplied AC power lead to this connector. Use only a power supply as marked on the rear panel of the unit. If you are in any doubt as to the compatibility of your power supply and the CD-D1x4, consult a qualified electrical engineer.

3 – Care of recordable media

The Compact Disc medium is a robust medium, and the discs can survive a good deal of physical abuse. However, there are precautions that you should take when handling CD-R discs which are different to those you should take when handling ordinary CDs.

Avoid touching the recording (non-label) side of a disc on which you will be recording. Recording on a disc requires a cleaner surface than playing back, and fingerprints, grease, etc. can cause errors in the recording process.

CD-R discs are more sensitive to the effects of heat and ultraviolet rays than ordinary CDs. It is important that they are not stored in a location where direct sunlight will fall on them, and which is away from sources of heat such as radiators or heat-generating electrical devices.

Always store CD-R discs in their “jewel cases” to avoid dirt and dust accumulating on their surfaces.

Do not put labels or protective sheets on the discs and do not use any protective coating spray.

When labeling CD-R discs, always use a soft oil-based felt-tipped pen to write the information. Never use a ball-point or hard-tipped pen, as this may cause damage to the recorded side.

Dirty discs may be cleaned using a soft dry cloth and/or a commercial CD cleaning fluid or ethyl alcohol. Do not use thinner, gasoline, benzene or LP cleaning fluid, as these will damage the disc.

If you are in any doubt as to the care and handling of a CD-R disc, read the precautions supplied with the disc, or contact the disc manufacturer directly.

It is important that you do not use CD lens cleaners (including CD-R or CD-ROM lens cleaners) with the CD-D1x4. The reason for this is that the drives in this unit rotate at a much higher speed than those of an audio CD unit, and accordingly, the pickup lenses of the drives may be damaged by an ordinary CD lens cleaner.

Discs recommended for use with the CD-D1x4

For optimum performance, we recommend the use of TEAC brand CD-R and CD-RW media.

Since the CD-D1x4 is capable of recording CD-R media at up to 16x speed, and high speed CD-RW media at up to 10x speed, make sure that media used with the CD-D1x4 can be written at these speeds.

Only use high speed CD-RW media (as marked on the packaging—an example of the logo is given in “About CD-R and CD-RW discs” on page 6) for high-speed operations on rewritable discs.

You may obtain an updated list of recommended media (CD-R and CD-RW discs) at the TASCAM Web site (www.tascam.com).

Power-up procedure

When the unit is first powered up using the power switch ①, it performs a self-check operation, and the screen shows the following:

```
Please wait...
```

followed by:

```
TASCAM
CD-D1x4
```

If the self-check is passed, the display shows the first menu screen, otherwise an error message is displayed.

```
COPY START?
(FAST)
```

NOTE

Wait until this message is displayed after power-on before attempting any operations with the CD-D1x4.

Inserting discs

Press the eject button of the **MASTER** or any of the slave drives to open the appropriate disc tray if the drive is not opened automatically by the unit.

Place discs, recording side down, in the disc tray.

To insert the discs into the **MASTER** drive, you may find it useful to place the front of the disc into the disc tray first, and then seat the back of the disc into the tray.

You can close the disc trays by pressing the eject button on the drive.

NOTE

*When inserting a disc into either the **MASTER** or slave drives, always wait until the drive indicator has gone out (the drive has recognized the disc) before attempting the next operation.*

Also, take note that it may take some time between key presses, etc. before the unit is ready to perform the next stage in the operation. To avoid any possible error in operation, take your time when pushing keys, and always wait until the CD-D1x4 is ready before proceeding to the next stage of an operation.

Power down

Before powering down the unit, eject discs from all drives (the eject mechanism requires power to work, and so you will not be able to eject the discs once power is turned off).

NOTE

Do not turn off the CD-D1x4 while writing to, or erasing any target disc (e.g. part of the way through a disc copy operation). If you do, the disc will be corrupt, and unusable.

Modes

The different modes available are:

- Copying discs (COPY START) with different verification modes available (see below)
- Test writing (SIMULATION)
- Extracting individual audio tracks from a source disc (TR EXTRACTION)
- Confirming whether blank discs are inserted (DISC ANALYZE)
- Erasing (DISC ERASE)—CD-RW discs only
- Play audio discs (PLAY AUDIO)
- System setup, including write speed selection (SETUP)

These are accessed in the order shown by repeated presses of the **MODE** key. Use the **ESCAPE** key to go backwards through the list.

Details of these modes are given later in this manual.

When the required mode is shown on the display, press the **ENTER** key to enter the mode.

When copying, there are additional copy modes available, providing verification and readability checking, as described below.

Finalized discs Although audio data may be written on a CD-R or CD-RW disc, a standard CD player will not be able to read the data (i.e. play back the

4 – Basic operations

audio) until a final table of contents (TOC) has been written at the start of the disc.

The process of writing this table of contents is known as “finalizing” and is performed automatically by the

CD-D1x4. Once this has been done, no further data can be written to the disc.

In the case of a CD-RW disc which has been finalized, the whole of the disc may be erased, and the disc re-used.

Additional copy modes

This is an option accessed from the `SETUP` menu, allowing you to set the different copy modes. There are five such modes:

- Copying (`COPY`), which copies the contents of a disc from the master drive to any slave drives with discs inserted.
- Verifying already copied data (`VERIFY`).

NOTE

The verify option is not available for the following types of disc: CD-DA (audio CDs), CD-ROM XA Form 2 discs and CD-EXTRA discs.

- Copying with verification (`COPY+V`). Copying followed by verification (as above). The same restrictions apply to the verification process as apply to verification alone. During this process, the display shows `COPY+V/C` during the copy phase of the operation, followed by `COPY+V/U` during the verification phase.
- Read check (`RD CHECK`). This provides a check as to whether the target discs can be read correctly after they have been copied.

NOTE

Note that when an audio disc is checked after copying or recording, no error will be shown unless the disc is very badly damaged (large audible errors). Any checking on a disc containing errors may take a significantly longer time than checking a good disc.

- Copy with read check (`COPY+R`). Copying, followed by the read check as described above. During this process, the display shows `COPY+R/C` during the copy phase, followed by `COPY+R/R` during the read check.

- 1 Press the `MODE` key until the display shows:

```
SETUP?  
 (MODE CHANGE)
```

- 2 Press `ENTER`, The screen should show:

```
>MODE SELECT?  
 (COPY)
```

The bottom line of the screen may be different, depending on the currently-set mode.

- 3 Press `ENTER` again.

- 4 Press the `MODE` key until the mode to be used appears on the screen (from the list above). Press `ENTER` to confirm the setting.

Pressing the `ESCAPE` key takes you back a level without changing anything.

- 5 If you select the verification or read check operations, you should press `ESCAPE` until the screen shows:

```
VERIFY START?
```

or

```
RD CHECK START?
```

- 6 Press `ENTER` to start the operation. The drive trays open automatically. Put the discs to be verified or checked into the drives, and when this is done, the drives have been closed, and the unit has recognized all the discs (the drive indicators have gone out), press `ENTER`.

The verification or read check process then starts.

NOTE

You should own the copyright, or have obtained the appropriate permission from the copyright owner or the rightful licensor. Unauthorized recording, reproduction or distribution thereof, may result in severe civil and criminal penalties under copyright laws and international copyright treaties.

This procedure copies the material from the disc (either an audio CD or a CD-ROM) in the **MASTER** drive to the CD-R or CD-RW disc in one of the slave drives.

Note, however, that when copying an audio disc, index markers greater than 1 will have their number set to 1 on the copied disc.

Setting the writing speed

The CD-D1x4 slave drives are capable of writing information to CD-R or CD-RW discs at one of three speeds: **FAST 16**, **MEDIUM 8**, or **SLOW 4**.

Speed with different media

Display	CD-R	CD-RW	High-speed CD-RW ^a
FAST 16	16x	4x	10x
MEDIUM 8	8x	4x	4x ^b
SLOW 4	4x	4x	4x

- Defined as 4-10x CD-RW
- Even though the display shows 8x, the drive is only capable of writing at 4x to CD-RW media in medium speed

The displayed nominal speed may differ sometimes from the actual speed of the writing operation, depending on circumstances. These circumstances (source material, target media, etc.) may also affect the maximum write speed.

The writing speed is used in copying, simulation and in track extraction operations and is set as described below.

Once the speed is selected, it is used in the CD copying and testing modes. It has no effect on the compare operations.

- 1 Press the **MODE** button until the display shows:

```

SETUP?
(MODE CHANGE)

```

- 2 Press **ENTER**, and then press **MODE** until the screen shows:.

```

>WRITE SPEED?
(FAST)

```

The bottom line of the screen may be different, depending on the speed that it currently set.

- 3 Press the **ENTER** key once more.

```

>>FAST ?
(x16)

```

- 4 Press the **MODE** key to cycle between **FAST**, **MEDIUM**, and **SLOW** mode.

There is also an **EXIT?** option that allows you to exit without changing anything, and pressing the **ESCAPE** key also takes you back a level without changing anything.

- 5 Press **ENTER** to confirm the speed selection.

NOTE

If you are in doubt what speed will work best, pick a slow speed first and experiment with the faster settings later. Usually, however, you should be able to copy most discs at the highest speed recommended for the particular brand of CD-R media you are using, as specified by the media manufacturer.

You may find it useful to test the copy procedure before committing yourself to an actual copy, however. See “Simulation” on page 15 for details.

Copying the disc

- 1 If the display does not show **COPY START?** with the current speed underneath, press **MODE** until it does. Press the **ENTER** key

```
INSERT
SOURCE DISC
```

The **MASTER** drive tray opens. Load the master disc and close the tray.

- 2 The trays of any slave drives which do not currently contain recordable discs will open.

Place target recordable discs in the slave disc trays (you don't have to put a disc in every tray).

If you decide that you do not want to make a copy at this stage, press the **ESCAPE** key to return to the mode selection menu.

The display alternates

```
INSERT
TARGET DISC
```

with:

```
PRESS ENTER
TO START
```

Note that these two displays above do not appear if a target disc has already been loaded in all slave drives.

- 3 When all the slave disc trays are filled and closed, wait until the discs are recognized by the drives (the indicators go out), the copy operation starts if all trays are filled. Note that if you are copying fewer than four discs at this time, you should press **ENTER** when you have loaded the slave drive with the last

disc you will use to copy onto. The display then shows.

```
ANALYZING SOURCE
```

as the **CD-D1x4** analyzes the source disc.

- 4 The copying process proceeds, and the screen shows:

```
COPY          15:26
CD-DA  ■■■000 40%
```

As copying progresses, the “bargraph” fills as the percentage does up. The time shown is the total time to be copied.

NOTE

Once a copy operation has started, although it can be stopped before the copy operation is complete, this will make the **CD-R** disc useless for any purpose.

Do not use warped discs or discs with off-center holes with the **CD-D1x4**.

While the copy operation is in progress, make sure that the **CD-D1x4** is not subjected to vibration or mechanical shocks.

You may press and hold the **ESCAPE** key for 5 seconds or more to abort the copying process. However, note that this will make the target discs unusable for further operations.

You can also press and hold the **ESCAPE** key for 5 seconds or more to abort verification or read check processes. Aborting these processes will not spoil the target discs.

If you have selected one of the verification options together with the copy process (see “Additional copy modes” on page 12), the name of these processes will be shown on the display as the process is carried out.

- 5 The drive trays open automatically when the copy procedure is finished.

The simulation operation is functionally similar to the copy operation, except that the writing of data to the slave discs is simulated. This is useful to make sure that data can be transferred at the selected rate between the master and slave discs.

- 1 Press the **MODE** key until the display shows:

```
SIMULATION?
          (FAST)
```

- 2 Press **ENTER**:

```
INSERT
SOURCE DISC
```

- 3 If the source disc is not already loaded, place the source disc in the **MASTER** disc tray and close the tray. The trays of any slave drives which do not currently contain recordable discs will open.

```
INSERT
TARGET DISC
```

with:

```
PRESS ENTER
TO START
```

These do not appear if a target disc is already present in all slave drives.

- 4 Place target recordable discs in the slave disc trays (you don't have to put a disc in every tray).

If you decide that you do not want to perform the simulation at this stage, press the **ESCAPE** key to return to the mode selection menu.

- 5 Close the trays, wait for the indicators to go out, and the operation starts. Note that if you are simulating a write of fewer than four discs, you should press **ENTER** when you have loaded the slave drive with the last target disc you will use for the simulation.

The CD-D1x4 starts to read and analyze the source disc.

```
ANALYZING MASTER
```

- 6 The simulation process proceeds, and the screen shows:

```
SIMULATION 15:26
CD-DA  ■■■■■ 40%
```

As the process continues, the “bargraph” fills as the percentage does up.

- 7 Pressing **ESCAPE** during a simulated copy halts the test copy process and returns to the main menu. Since the test process does not write to disc, the target discs are not affected in any way.

Track extraction

This mode is used with audio CDs for extracting a number of tracks from a source disc and copying them to the target discs. It has no meaning with other types of disc.

- 1 Press the **MODE** key until the display shows the following:

```
Tr  EXTRACTION?
                (FAST)
```

- 2 Press **ENTER** to proceed with the track extraction. The **MASTER** drive disc tray opens automatically:

```
INSERT
SOURCE DISC
```

- 3 Insert the source disc and close the master drive disc tray.

```
INSERT
TARGET DISC
```

- 4 Insert recordable target discs into the slave drive(s) (the drive trays open automatically). If you are not using every slave drive, simply close any empty trays. Close the trays and wait for all indicators to go out.

- 5 Press **ENTER** (or **ESCAPE** to exit). The source disc is then analyzed to discover if it is an audio disc, and if so, how many tracks are on it:

```
ANALYZING SOURCE
```

- 6 After this analysis, you can extract tracks one at a time. The bottom line shows the current track which you can extract, followed by the total number of tracks on the source disc and the total time so far of the selected tracks in the list if the current track is selected. This allows you to judge in advance whether adding a track will add too much data to the target disc:

```
EXTRACT TRACK?
Tr   2/14  14:56
```

The screen above shows that the current track is track 2, out of a total of 14 tracks on the source disc.

- 7 Press **ENTER** to add the currently-shown track to the list of tracks to be copied, and move to the next track on the source disc.

Press **MODE** to skip the currently-shown track (it will not be added to the list) and move to the next track in the list.

- 8 When the last track is reached, the display shows

```
END EXTRACTION?
Tr   4      24:32
```

Press **ENTER** to continue with the extraction of the tracks that have been selected so far, or **MODE** to return to the start of the source CD again and remake the list.

NOTE

Note that **END EXTRACTION?** in this screen actually asks whether the selection process should be ended and the extraction process should start.

- 9 If you have pressed **ENTER** to continue, the display shows **SURE ?**. Press **ENTER** again to confirm that the track copying will start.
- 10 As copying of the tracks to be extracted progresses, the total time of the tracks to be copied, and a percentage of the copying done so far is shown on the display.

```
COPY          24:32
CD-DA  ■■■00040%
```

When the copy is finished, the display shows **Tr Extraction?**.

NOTE

Recording done in this way is performed in the **Disc At Once (DAO)** mode. A 2-second gap is added between tracks automatically.

You may press and hold the **ESCAPE** key for 5 seconds or more to abort the copying process. However, note that this will make the target discs unusable for further operations.

Copy-protection

The CD-D1x4 allows copy-protection to be applied to audio discs produced using the unit.

There are three settings:

- **1GENERATION** (single-generation copying), where one digital copy (“child”) can be made from the recorded disc, but no digital copies (“grandchildren”) can be made from the child.
- **FREE** (may be freely copied), where no copy-protection is applied to the recorded disc.
- **PROHIBIT** (copy prohibited) which prevents any digital copies being made from the recorded disc

- 1 Press the **MODE** button until the display shows:

```
SETUP?
(MODE CHANGE)
```

- 2 Press **ENTER**, and then press **MODE** until the screen shows:

```
>COPY ID?
(1GENERATION)
```

- 3 Press **ENTER**, and then use the **MODE** key to choose between **1GENERATION**, **FREE** and **PROHIBIT** as explained above.
- 4 Press **ENTER** to confirm the setting.

Audio playback

Since it is impossible to make a bit-by-bit comparison of audio CDs, this function is provided for you to “audition” a CD copy, using a pair of headphones connected to the headphone jack of the **MASTER** or one of the slave drives.

Any standard headphones with a 3.5 mm stereo jack may be used. The volume is adjusted using the drive’s volume control (turn to the right to increase the volume, and to the left to decrease the volume).

- 1 Press the **MODE** key until the display shows the following:

```
PLAY AUDIO?
```

- 2 Press **ENTER**:

```
SELECT DRIVE
MASTER?
```

- 3 Press **ENTER** to select the **MASTER** drive, or keep pressing **MODE** until the display shows the number of the slave drive you want to use, and then press **ENTER**.
- 4 The disc tray of the selected drive opens automatically, and you should then insert the disc and close the tray.
- 5 Press **ENTER** to start playback. While the disc is being played back:

- Use the **ESCAPE** key to stop playback
- Press and hold the **MODE** key to rewind through a track (playback is muted)

- Press and release the **MODE** key to go back a track
- Press and hold the **ENTER** key to fast forward through a track (playback is muted)
- Press and release the **ENTER** key to go forward a track

The display shows the current track and the number of tracks on the disc, as well as the elapsed time on the current track:

```
TRACK      02/12
PLAY       03:13
```

While playback is stopped:

- Use the **ESCAPE** key to go up one level in the menu system.
- Press and release the **MODE** key to move backward a track
- Press and release the **ENTER** key to go forward a track

When playback is stopped, the display shows the total number of tracks on the disc, as well as the total recorded time of the disc:

```
TRACK      12/12
TIME       54:23
```

NOTE

If the copied CD contains audio errors, you will be able to hear them, but no message will appear on the display. If a copied CD contains audible errors, you may want to consider re-recording at a lower speed, which will almost certainly reduce the error rate.

7 – Other functions

Erasing discs

This applies to CD-RW media only. You cannot erase CD-R discs that have been recorded.

- 1 Press the **MODE** key until the display shows:

```
DISC ERASE?  
      (CD-RW)
```

- 2 Press **ENTER**. The display shows **SURE ?**. Press **ENTER** for the next stage, otherwise press **MODE**. If there is a slave drive into which a target disc has not been loaded, the display alternates:

```
INSERT  
TARGET DISC
```

with

```
PRESS ENTER  
TO START
```

- 3 Insert any discs to be erased in the slave drives, close the trays and wait for the indicators to go out. Then press **ENTER**.

As the discs are erased, the display shows:

```
DISC ERASE...  
Please wait...
```

NOTE

You should take care that you do not leave any CD-RW discs that you want to retain in the slave drive trays!

Finding out about your CD-D1x4

In the event of any questions about your CD-D1x4, you may need to discover the drive type and firmware versions of the five drives installed in the unit.

- 1 Press the **MODE** button until the display shows:

```
SETUP  
      (MODE CHANGE)
```

- 2 Press **ENTER**, and then press **MODE** until the screen shows:

```
>DRIVE INQUIRY?
```

- 3 Press **ENTER**. The display shows information (maker, model and firmware version) about the master drive (this may be different from that shown here):

```
MASTER  
TEAC
```

```
MASTER  
CD-540E
```

```
MASTER  
3.0A
```

- 4 Press **MODE** to see similar information about slave drives:

```
DRIVE 1  
TEAC
```

You can press **ESCAPE** to go up a level at any time during this enquiry.

Finding out the main unit version number

- 1 Press the **MODE** button until the display shows:

```
SETUP  
      (MODE CHANGE)
```

- 2 Press **ENTER**, and then press **MODE** until the screen shows:

```
>F/W VERSION?
```

- 3 Press **ENTER**. The screen shows the model and major firmware version (the number shown may differ from the one shown here):

```
CD-D1x4  
Ver 1.00
```

- 4 Press **MODE** to view the hardware information (the maximum speed available and the model hardware serial number):

```
H/W INFO          x16
1110880000000000
```

- 5 Press **MODE** once more to view the number of discs successfully copied (OK) and the

number of discs for which copying has been attempted (TOTAL) so far. Note that discs on which track extraction has been performed are not included in these totals.

```
OK                1321
TOTAL             1334
```

The Session Mode option

The **SESSION MODE** option should always be left as **CLOSE**.

There is one exception to this: if you are adding data to audio discs using a computer to make CD-EXTRA discs. Consult the reference manual of your computer CD-R software for details.

Cascading

When two units are cascaded, the master unit can use up to four slave drives of the slave unit.

- 1 **With the two power switches on each unit turned OFF, use the supplied cascade cable to link the two units.**
- 2 **Set the switch on the rear of one unit to MASTER, and on the other to SLAVE. Note that if you set both to MASTER or both to SLAVE, neither unit will work properly.**
- 3 **Turn on the rear power switches and then turn on the front power switches (always turning on the slave first).**

The slave unit shows Slave Mode on the display.

The slave front panel controls and display are disabled, except for the drive eject keys, headphone jacks and volume controls (which can be used at the appropriate points in the different procedures).

When the cascade master is cycling through the slave drives, it uses eight drives instead of four (slave drive 1 on the slave unit becomes drive 5, etc.).

All other operations are carried out as usual.

NOTE

*If you turn off the **SLAVE** unit when two units are connected in cascade mode, the **MASTER** unit cannot be used.*

To clear an error

When an error is shown, the unit beeps continuously to attract your attention. To clear the error and stop the beeping, open the drive mentioned in the error message.

Error messages

`ERROR SOURCE` alone, or `ERROR DRIVE` `x` alternating with `ERROR SOURCE` may be shown in the case of a dirty, damaged or scratched disc being loaded into the **MASTER** drive. Check that the disc is properly loaded, and clean the disc if necessary.

In other cases, `ERROR DRIVE` `x` or `ERROR SOURCE` is shown on the top line, with one of the errors below shown on the bottom line if one of the drives encounters an error during a process. `x` refers to the number of the slave drive.

`CODE` `xxxx` is shown if an internal error occurs. Make a note of the number represented by `xxxx` and contact your TASCAM supplier (the number is used by the service engineers, and may be shown together with another message).

`SOURCE ANALYZE` is shown if an error occurs while analyzing the source disc. Check the master drive loading, and clean the disc if necessary.

`VERIFY ERROR` is shown if an error occurs while verifying a recorded disc. Try again with another disc.

`DISC ERROR` is shown when an unrecognizable disc (for example one that was created when power was turned off during a copy operation) is inserted.

`DISC TYPE` is shown if the source disc to be copied is of the wrong type to be copied (or it may be copy-protected). Only copy discs as specified in this manual.

`JOB ABORTED` indicates a process halted by you before it has come to an end. No action necessary.

`DATA SIZE` is shown in verification operations if there is a difference between the source and target discs.

`TIME OUT` indicates a time-out error with one of the drives. Try again.

`CAPACITY ERROR` indicates that the target disc is the wrong size for the data you are trying to copy. Make sure the target disc is the right size for the data you are copying. The standard maximum length of an audio CD is set at 74 minutes. However, some commercial CDs are recorded with a running time a little longer than this.

If any of these errors occur, correct the problem, if possible (replace the offending disc correctly in the disc tray, try again with a different disc, etc.) before attempting the copy operation again.

Operational specifications

Unit	Professional CD and CD-ROM duplicator
Types of media that may be copied ^a	CD-DA (audio CDs ^b) and CD-ROM (ISO9660 standard, etc.)
Types of recordable media	CD-R, CD-RW and high-speed CD-RW
Maximum write speed	16 times (CD-R), 10 times (high-speed CD-RW), 4 times (CD-RW)
Other speeds	8 times, 4 times (CD-R), 4 times (CD-RW)
Audio playback	Through drive headphone outputs
Display	2 x 16 alphanumeric backlit display

- a. Subject to appropriate copyright permission being obtained
- b. Subcode data other than timing information (e.g. CD-TEXT and CD-G information) will not be copied

Physical specifications

Dimensions (w x h x d)—excluding feet	482 x 177 x 385 mm (19 x 7 x 15.1 in.)
Weight	16.5 kg (36 lbs)
Supplied accessories	Power cord, cascade cable, rack mount screw kit
Voltage requirements and power consumption:	USA/Canada 120 VAC @ 60 Hz, 700 mA (80 W) Korea 220VAC @ 60 Hz, 380 mA (80 W) Europe/UK 230 VAC @ 50 Hz, 380 mA (80 W) Australia 240 VAC @ 50 Hz, 380 mA (80 W)

Dimensional drawing

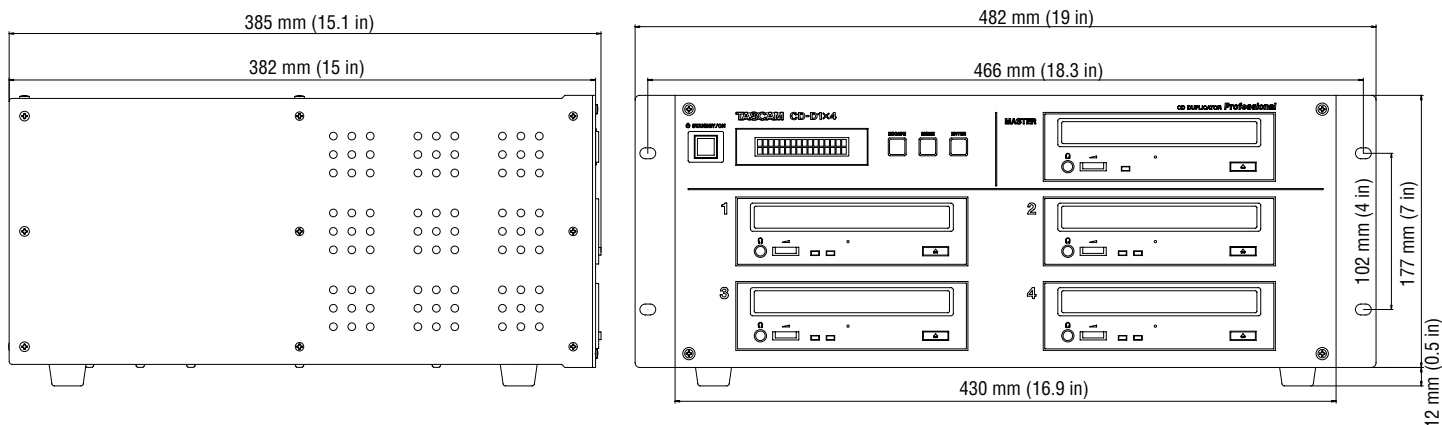

TASCAM

TEAC Professional Division

CD-D1x4

TEAC CORPORATION

Phone: (0422) 52-5082

3-7-3, Nakacho, Musashino-shi, Tokyo 180-8550, Japan

TEAC AMERICA, INC.

Phone: (323) 726-0303

7733 Telegraph Road, Montebello, California 90640

TEAC CANADA LTD.

Phone: 905-890-8008 Facsimile: 905-890-9888

5939 Wallace Street, Mississauga, Ontario L4Z 1Z8, Canada

TEAC MEXICO, S.A. De C.V

Phone: 5-851-5500

Campesinos No. 184, Colonia Granjes Esmeralda, Delegacion Iztapalapa CP 09810, Mexico DF

TEAC UK LIMITED

Phone: 01923-819699

5 Marlin House, Croxley Business Park, Watford, Hertfordshire. WD1 8TE, U.K.

TEAC DEUTSCHLAND GmbH

Phone: 0611-71580

Bahnstrasse 12, 65205 Wiesbaden-Erbenheim, Germany

TEAC FRANCE S. A.

Phone: 01.42.37.01.02

17 Rue Alexis-de-Tocqueville, CE 005 92182 Antony Cedex, France

TEAC BELGIUM NV/SA

Phone: 0031-162-510210

Oeverkruid 15, NL-4941 VV Raamsdonksveer, Netherlands

TEAC NEDERLAND BV

Phone: 0162-510210

Oeverkruid 15, NL-4941 VV Raamsdonksveer, Netherlands

TEAC AUSTRALIA PTY.,LTD. A.B.N. 80 005 408 462

Phone: (03) 9672-2400 Facsimile: (03)9672-2249

280 William Street, Port Melbourne, Victoria 3000, Australia

TEAC ITALIANA S.p.A.

Phone: 02-66010500

Via C. Cantù 11, 20092 Cinisello Balsamo, Milano, Italy